



SOUNDSTREAM

OWNER'S MANUAL

TRX2.210 / 2.320 / 2.440 / 2.550 / 2.640 / 2.820

TRX4.300 / 4.420 / 4.640 / 4.880

TRX5.670

SOUNDSTREAM

TABLE OF CONTENTS

INTRODUCTION.....	2
FEATURES & SPECIFICATIONS.....	3
CONTROLS & FUNCTIONS.....	4 ~ 9
PLANNING & MOUNTING YOUR SYSTEM.....	10 ~11
WIRING DIAGRAM.....	12 ~ 14
2 Channel(MONO/STEREO/TRI MODE).....	12
4 Channel(2/3/4 Channel MODE).....	13
5 Channel(3/4 Channel/TRI MODE).....	14
ADJUSTING & TUNING.....	15
TROUBLE SHOOTING.....	16



INTRODUCTION

Amplifier's provide high-performance sound reinforcement for you'r mobile audio equipment. The Multi-Mode bridging capabilities allow flexibility in hosting several different speaker configurations.

To achieve optimum performance, it is highly recommended that you read this Owners Manual before beginning installation.

SOUNDSTREAM

FEATURES

- IDI™ (Intelligent Distress Indicator) gives a visual indication of the amplifier's protection status
- Fully regulated MOSFET power supply
- PWM circuitry
- Tri-guard amplifier protection
- Platinum RCA inputs and outputs
- Bi-linear selectable crossovers for inputs and outputs (Hi/Full/Low)
Continuously variable high and low-pass crossovers
- Subwoofer equalizer control switch
- Viable phase shift control (0 - 180 degree)
- OEM floating ground input
- Platinum 4-gauge power connectors
- Tri-mode operation
- Includes remote bass boost control (TRX2.440/2.550/2.640/2.820/5.670)

SPECIFICATIONS

MODEL	CHANNEL	RMS @ 4 OHM	@ 2 OHM	(BRIDGE) @ 4 OHM	FUSES	DIMENSIONS
TRX2.210	2	70W x 2CH	105W x 2CH	210W x 1CH	30A X 1	12.9"x2.6"x11"
TRX2.320	2	100W x 2CH	160W x 2CH	320W x 1CH	40A X 1	14.9"x2.6"x11"
TRX2.440	2	130W x 2CH	220W x 2CH	440W x 1CH	25A X 2	16.8"x2.6"x11"
TRX2.550	2	175W x 2CH	275W x 2CH	550W x 1CH	30A X 2	18.8"x2.6"x11"
TRX2.640	2	210W x 2CH	320W x 2CH	640W x 1CH	25A X 3	22.8"x2.6"x11"
TRX2.820	2	250W x 2CH	410W x 2CH	820W x 1CH	30A X 3	24.8"x2.6"x11"
TRX4.300	4	50W x 4CH	75W x 4CH	150W x 2CH	20A X 2	16"x2.6"x11"
TRX4.420	4	70W x 4CH	105W x 4CH	210W x 2CH	30A X 2	17.6"x2.6"x11"
TRX4.640	4	100W x 4CH	160W x 4CH	320W x 2CH	25A X 3	20"x2.6"x11"
TRX4.880	4	130W x 4CH	220W x 4CH	440W x 2CH	30A X 3	22.8"x2.6"x11"
TRX5.670	5	70W x 4CH + 190W x 1CH	105W x 4CH + 250W x 1CH	210W x 2CH + 250W x 1CH	40A X 2	26.3"x2.6"x11"



Controls & Functions

TRX2.210 / 2.320 / 2.440 / 2.550 / 2.640 / 2.820

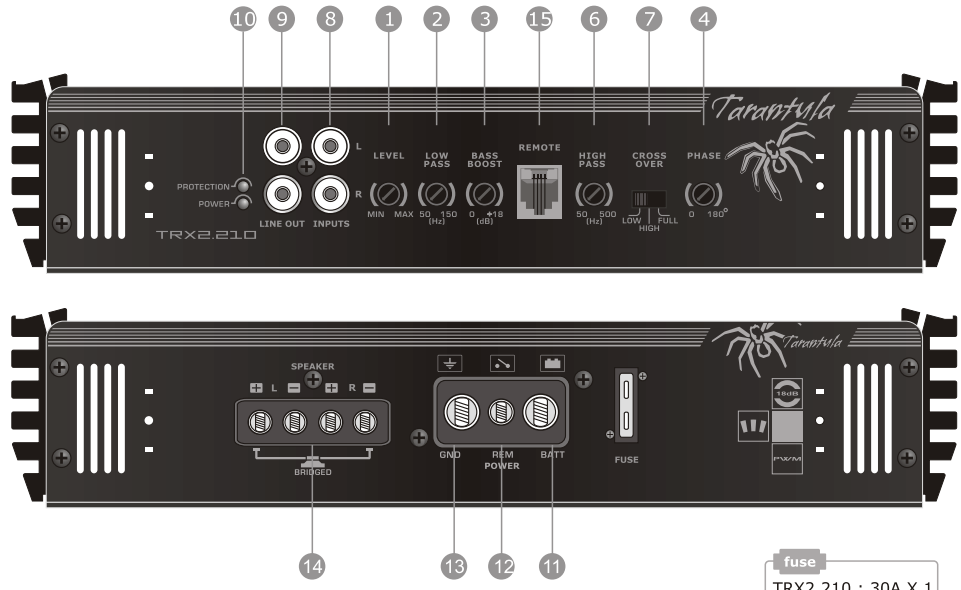

fuse	
TRX2.210	: 30A X 1
TRX2.320	: 40A X 1
TRX2.440	: 25A X 2
TRX2.550	: 30A X 2
TRX2.640	: 25A X 3
TRX2.820	: 30A X 3

TRX4.300 / 4.420 / 4.640 / 4.880

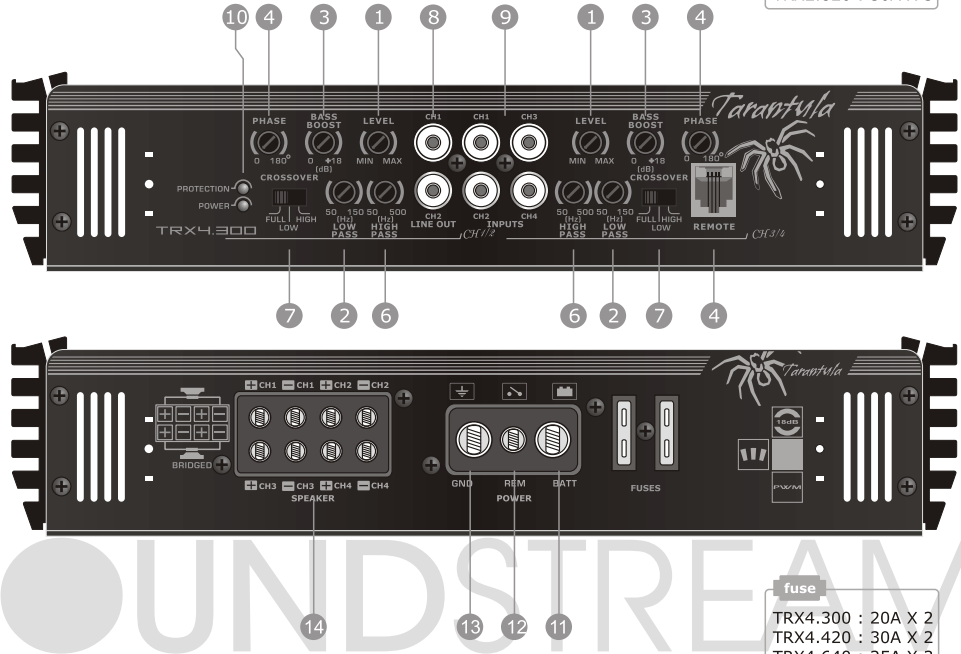



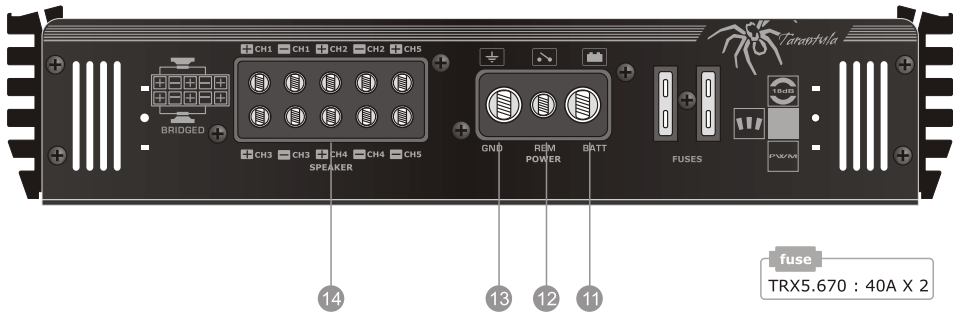
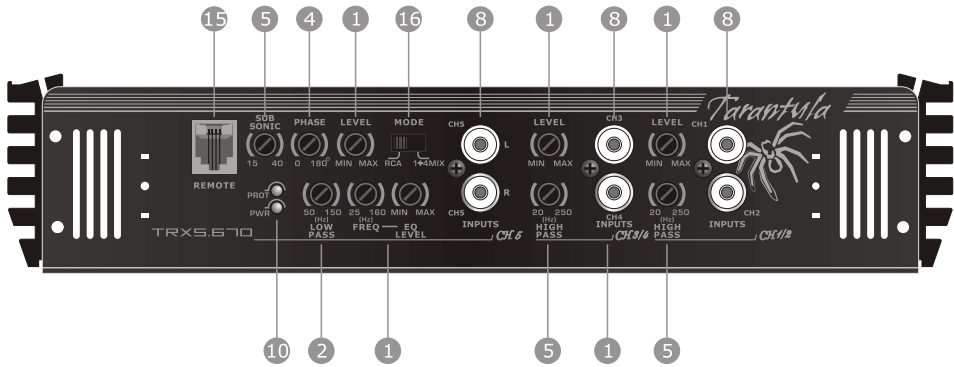

fuse	
TRX4.300	: 20A X 2
TRX4.420	: 30A X 2
TRX4.640	: 25A X 3
TRX4.880	: 30A X 3

Controls & Functions

TRX5.670



Controls & Functions

1. Input Level Adjustment	<p>LEVEL</p>  <p>MIN MAX</p>	<p>LEVEL</p>  <p>MIN MAX</p>	  <p>25 160 MIN MAX (Hz) FREQ — EQ LEVEL</p>
<p>TRX2.210/2.320/2.440/2.550/ TRX2.640/2.820 TRX4.300/4.420/4.640/4.880</p>		<p>TRX5.670</p>	

This control adjusts the amplifier's input sensitivity. Input sensitivity is variable from 200 Millivolts to 8 volts. Clockwise increases sensitivity. Counterclockwise decreases sensitivity. The amplifier can be driven to full power with a wide range of signal levels. A lower signal level will require increased sensitivity for full power. A higher signal level will require decreased sensitivity. Avoid setting sensitivity lower than necessary as this would introduce unwanted distortion.

2. Low Pass Filter Control	<p>LOW PASS</p>  <p>50 150 (Hz)</p>
-----------------------------------	--

Variable Low-Pass Filter (50Hz-150Hz) :
Adjust variable crossover frequency with control as desired. The amplifier input circuit filters out everything above the frequency selected, so only the deepest bass notes are amplified.

3. Bass Boost Control	<p>BASS BOOST</p>  <p>0 +18 (dB)</p>
------------------------------	---

By using the bass boost function, bass notes at 35Hz - 80Hz are emphasized as much as 18dB.



4. Phase Shift Control	<p>PHASE</p>  <p>0 180°</p>
-------------------------------	--

PHASE SHIFT SWITCH (0 AND 180 DEGREES):
Allows you to change the phase of your subwoofer from 0 to 180 degrees to help compensate for timing differences between drivers.

5. Subsonic Filter Control	<p>SUB SONIC</p>  <p>15 40</p>
-----------------------------------	---

Variable Subsonic Filter (15Hz - 40Hz) :
The Subsonic filter will roll off all of the unwanted frequencies below 15Hz - 40Hz. This will allow the amplifier to use that wasted power on the audible bandwidth.

Controls & Functions

<h3>6. High Pass Filter Control</h3>	
<p>TRX2.210/2.320/2.440/2.550/ TRX2.640/2.820 TRX4.300/4.420/4.640/4.880</p>	<p>HIGH PASS</p>  <p>50 500 (Hz)</p>
<p>TRX5.670</p>	 <p>20 250 (Hz) HIGH PASS</p>

Variable High Pass Filter (50Hz - 500Hz) :
 For use as a dedicated mid high range channel, set Filter Switch To "HPF".
 The Input Circuit filters out all Frequencies Below 50Hz ...250Hz.

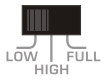
<h3>7. Cross over Switch</h3>	
<p>CROSS OVER</p>  <p>LOW FULL HIGH</p>	

Adjust the crossover for your chosen installation method.
LOW: Low pass filter-only bass tones(50Hz-150Hz)go to speakers. Use with woofer or sub-woofer. **FULL:** No filter-all tones go to speakers. Use with full-range speakers, or with external crossovers. **HIGH:** High pass filter-blocks very low tones(50Hz-600Hz)from the speakers.

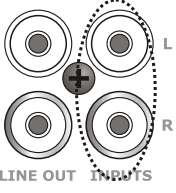
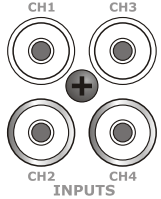
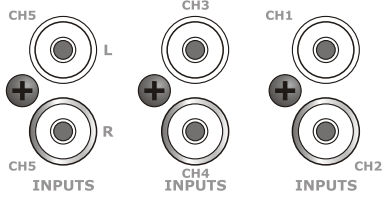
<h3>7. Low Level Input RCA jacks</h3>		
 <p>LINE OUT INPUTS</p>	 <p>CH1 CH2 CH3 CH4 INPUTS</p>	 <p>CH1 CH2 CH3 CH4 CH5 INPUTS</p>
<p>TRX2.210/2.320/2.440/2.550/ TRX2.640/2.820</p>	<p>TRX4.300/4.420/4.640/4.880</p>	<p>TRX5.670</p>

These inputs are for signal cables from the source. Always use high quality shielded RCA cables.

<h3>9. Low Level OUT RCA jacks</h3>	
 <p>LINE OUT INPUTS</p>	 <p>CH1 CH2 LINE OUT</p>
<p>TRX2.210/2.320/2.440/2.550/ TRX2.640/2.820</p>	<p>TRX4.300/4.420/4.640/4.880</p>

The LINE OUT allows you to build multiple amplifier systems without having to use splitter cords to distribute the signal. Now it is simply a matter of bringing one set of RCAS into the first amplifier, then using the line out RCA jacks as the feed to the next amplifier.



Controls & Functions

10. LED Indicator



PWR(Power): This GREEN LED will illuminate when the amplifier is turned "ON". If it fails to illuminate, check the power connections to the Amplifier and fuses.

PROT(Protection): The amplifier protection circuitry will disable the amplifier if input overload, short circuit or extremely high temperature conditions are detected. When the protection mode is in operation, the LED indicator on the side panel will be illuminated, indicating the amplifier has gone into a self-preservation mode.

If you observe that the Protection LED is lit, please check the system carefully to determine what has caused the protection circuit to engage. The amplifier can be reset by turning the remote power off and then on again. If the amplifier shut down due to a thermal overload condition, please allow it to cool down before restarting. If the amplifier shut down because of an input overload or short circuit, be sure to repair these conditions before attempting to power up the amplifier again.

11. B+ Terminal (Battery positive)

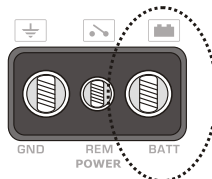

Due to the power requirements of the Amplifier, this connection should be made directly to the positive(+) terminal of battery. For safety measure, install an in-line fuse Holder (not included) as close to the battery positive(+) terminal as possible with an ampere rating ; not to exceed total value of fuses in Amp.

12. Remote Power On

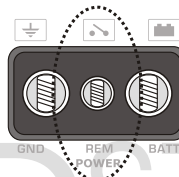

Controls & Functions

13. B- Terminal (Chassis ground)

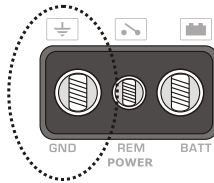

To avoid unwanted ignition noise caused by ground loops, it is essential that the Amplifier be grounded to a clean, bare, metal surface of the vehicles chassis.

Note : GROUND WIRE SHOULD NOT BE EXTENDED MORE THAN 3 FT (1 METER).

14. Speaker terminals

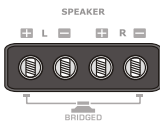

TRX2.210/2.320/2.440/2.550/
TRX2.640/2.820

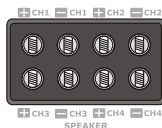

TRX4.300/4.420/4.640/4.880

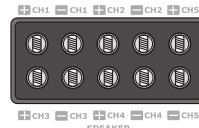

TRX5.670

15. Remote Control Input



Remote Bass Boost Control : This control adjusts the Bass Boost gain for the amplifier's speaker output (0 ~+18dB)

16. Remote Control Input



1-4CH : When signal is put into RCA input of CH1/2/3/4, 5CH Operates
RCA : When signal is put into RCA input of CH1/2/3/4/5, 5CH Operates

Planning and Mounting Your System

The mounting position of your Amplifier will have a great effect on its ability to dissipate the heat generated during normal operation. Under normal conditions, the heatsink will dissipate sufficient heat to avoid thermal shutdown. However please do not install the amplifier in a wooden box or similar device as this will prevent heat dissipation into the atmosphere.

Temperatures in car trunks have been measured as high as (155°F) in the summer time. since the thermal shut-down point for the amplifier is (158°F) it is easy to see that it must be mounted for maximum cooling capability. To achieve maximum advantage of convection air flow in an enclosed trunk, mount the amplifier in a horizontal position.

Cooling requirements are considerably relaxed when mounting inside the passenger compartment since the driver will not often allow temperatures to reach a critical point. Floor mounting under the seat is usually satisfactory as long as there is at least 1 inch of clearance (2.54 cm) above the Amplifier's fins for ventilation.

- A. Select a suitable location that is convenient for mounting, is accessible for wiring. And has ample room for air circulation and cooling.
- B. Use the amplifier as a template to mark the mounting holes. Remove the Amplifier and drill holes. Use extreme caution, inspect underneath surface before drilling!
- C. Secure the Amplifier using the screws provided.

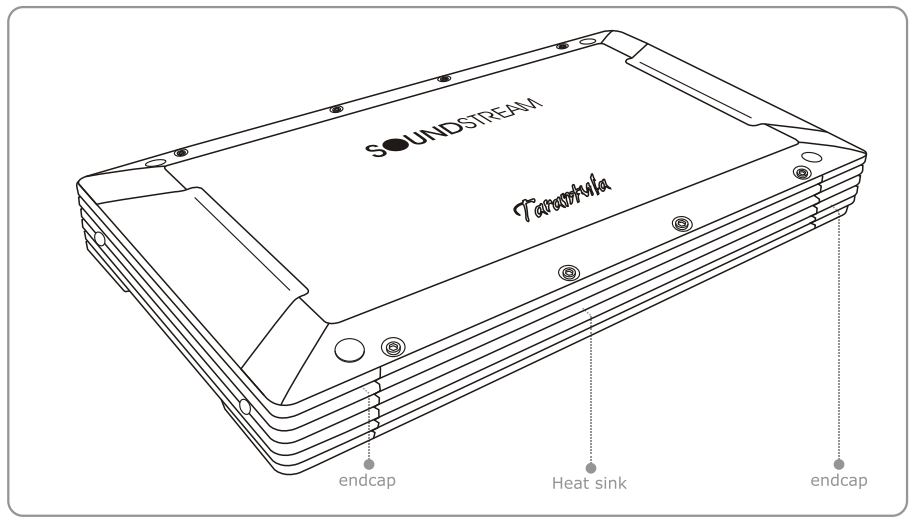

SOUNDSTREAM

Planning and Mounting Your System

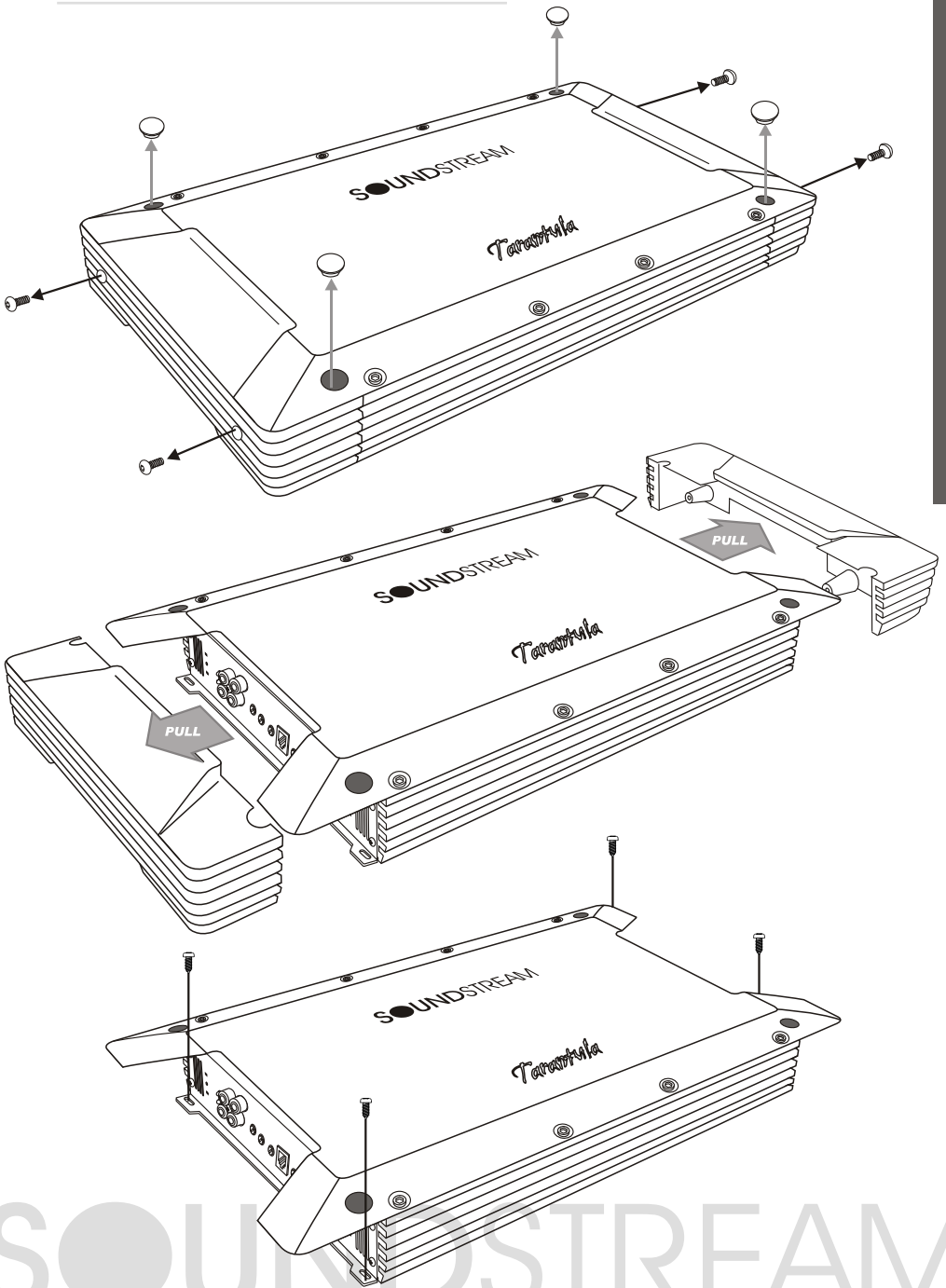

SOUNDSTREAM

TRX2.210 / 2.320 / 2.440 / 2.550 / 2.640 / 2.820

Mono mode

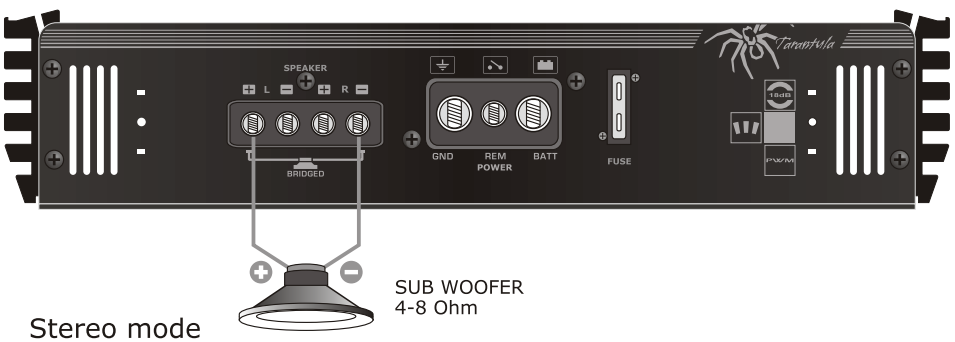

Stereo mode

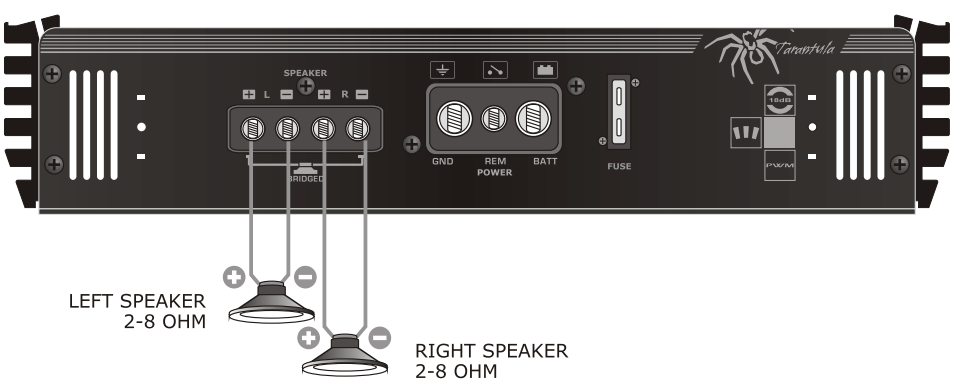

Tri mode

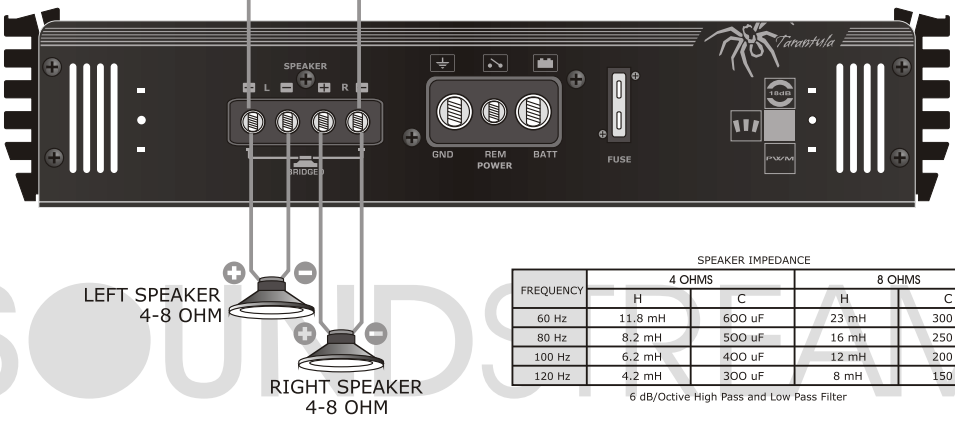

FREQUENCY	SPEAKER IMPEDANCE			
	4 OHMS		8 OHMS	
	H	C	H	C
60 Hz	11.8 mH	600 uF	23 mH	300 uF
80 Hz	8.2 mH	500 uF	16 mH	250 uF
100 Hz	6.2 mH	400 uF	12 mH	200 uF
120 Hz	4.2 mH	300 uF	8 mH	150 uF

6 dB/Octave High Pass and Low Pass Filter

TRX4.300 / 4.420 / 4.640 / 4.880

2Channel mode

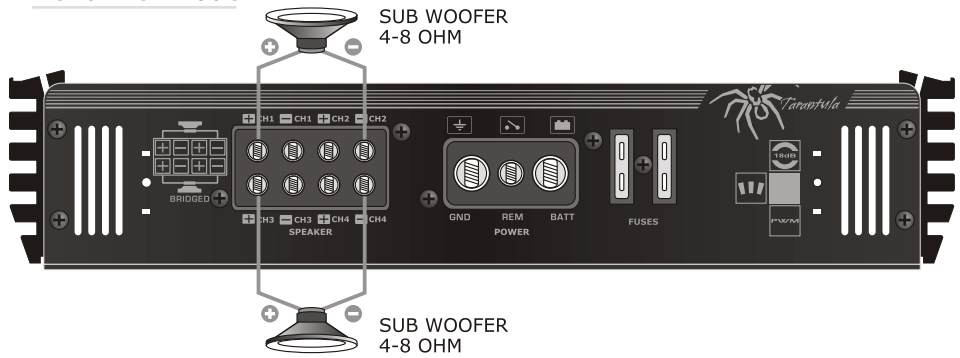

3Channel mode

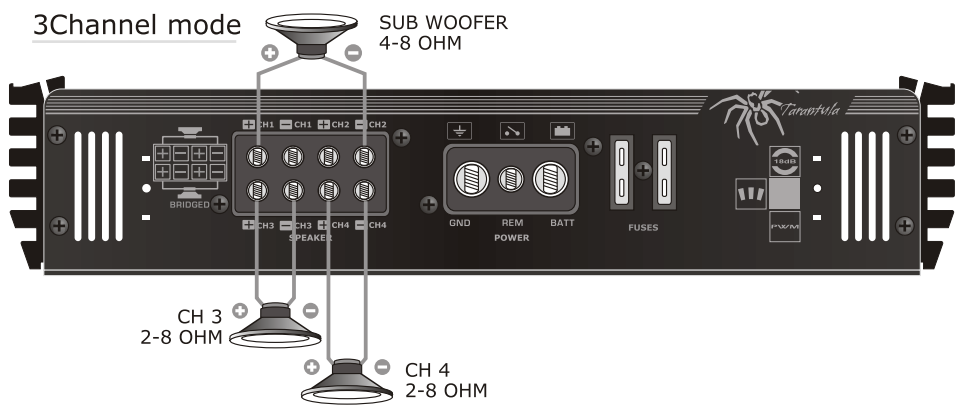

4Channel mode

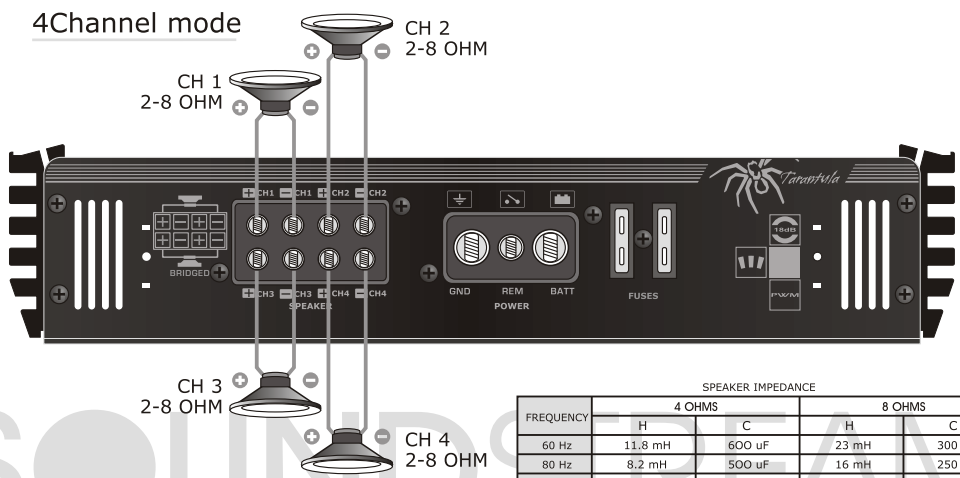

FREQUENCY	SPEAKER IMPEDANCE			
	4 OHMS		8 OHMS	
	H	C	H	C
60 Hz	11.8 mH	600 uF	23 mH	300 uF
80 Hz	8.2 mH	500 uF	16 mH	250 uF
100 Hz	6.2 mH	400 uF	12 mH	200 uF
120 Hz	4.2 mH	300 uF	8 mH	150 uF

6 dB/Octave High Pass and Low Pass Filter

TRX5.670

3Channel mode

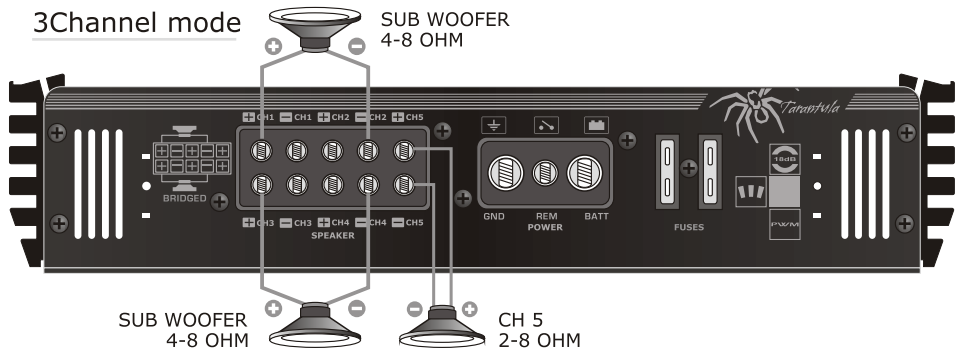

5Channel mode

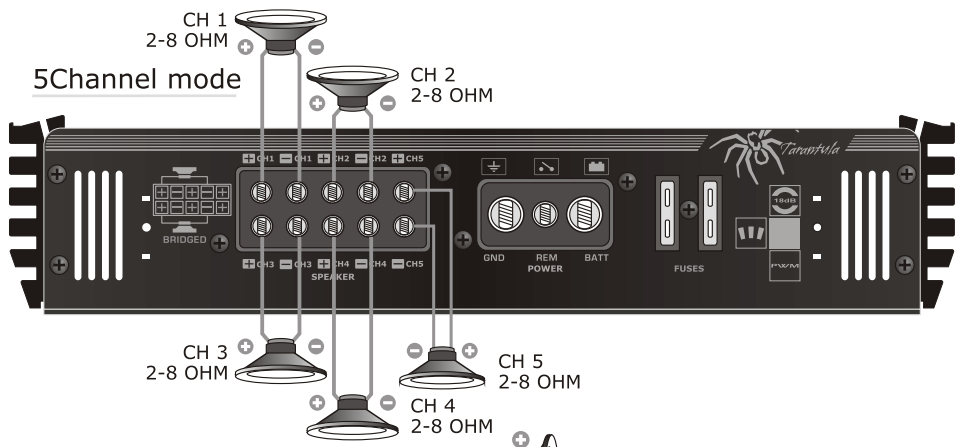

TRI mode

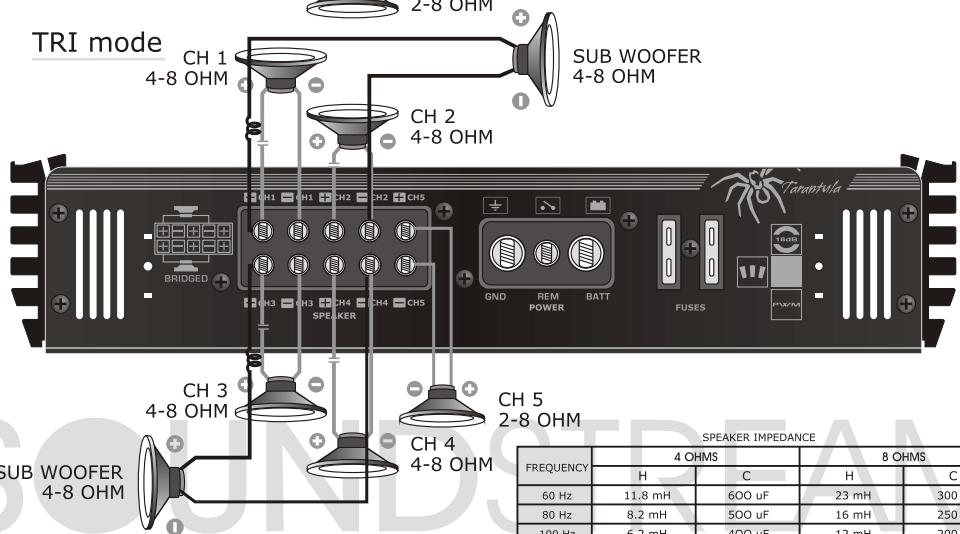

FREQUENCY	SPEAKER IMPEDANCE			
	4 OHMS		8 OHMS	
	H	C	H	C
60 Hz	11.8 mH	600 uF	23 mH	300 uF
80 Hz	8.2 mH	500 uF	16 mH	250 uF
100 Hz	6.2 mH	400 uF	12 mH	200 uF
120 Hz	4.2 mH	300 uF	8 mH	150 uF

6 dB/Octave High Pass and Low Pass Filter

Tuning on the Amplifier

The amplifier automatically turns on a few seconds after you turn your vehicle's ignition switch to ACC or ON or turn on your auto sound system, depending on how you wired the system. The POWER indicator on the top of the amplifier lights when the amplifier is on.

Important : Your amplifier requires 30 amps or more of power from your vehicle's battery during operation. To protect your battery from discharging, do not operate the amplifier unless your vehicle is running.

Adjusting The Audio Level

For the best performance, you must set GAIN (MIN / MAX) on the side of the amplifier to adjust the level of the audio signals that enter the amplifier.

1. Use a screwdriver to turn GAIN (MIN / MAX) fully counterclockwise to MIN.
2. Turn the auto sound system's volume control to about one-third of its full range.
3. Adjust GAIN (MIN / MAX) to a comfortable listening level.
4. Turn up the auto sound system's volume control until the sound begins to distort. Then immediately turn the volume down to a point just before where the distortion began.

Caution : Never turn up the auto sound system's volume control more than needed to adjust the audio level, more than two thirds of its maximum volume.

5. Adjust GAIN (MIN / MAX) until the sound is at the maximum level you want the amplifier to produce.
6. Adjust the auto sound system's volume control to a comfortable listening level.

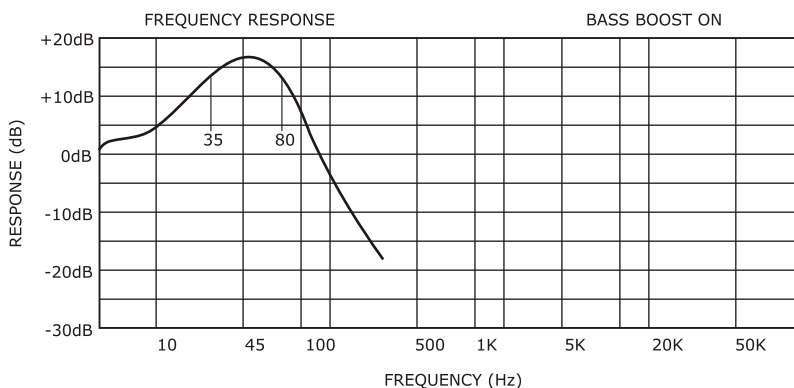

NOTE: Raising the Bass frequency allows higher frequencies to reach the bass speakers while blocking lower frequencies from midrange speakers. Lowering the Bass frequencies allows lower frequencies to reach the midrange speakers while blocking higher frequencies from bass speakers.

Trouble Shooting

SYMPTOMS	CHECK	REMEDY
NO SOUND	Is the power LED illuminated? (NO)	Check all fuses to amplifier. Be sure Turn-on lead is connected Check signal leads. Check gain control. Check Tuner/Deck volume level. Clean contacts on fuse holders.
	Is the Diagnostic LED illuminated? (YES)	Check for speaker short or amplifier overheating.
AMP NOT SWITCHING ON	No power to power wire	Repair power wire or connections.
	No power to remote wire with receiver on	Check connections to radio.
	Burnt or broken fuse	Replace fuse
NO SOUND IN ONE CHANNEL	Check Speaker Leads	Inspect for short circuit or an open connection.
	Check Audio Leads	Reverse Left and Right RCA inputs to determine if the problem is occurring before the amp.
AMP TURNING OFF MEDIUM / HIGH VOLUME	Check Speaker load impedance	Be sure proper speaker load impedance recommendations are observed. (If you use an ohmmeter to check speaker resistance, please remember that DC resistance and AC impedance may not be the same.)
PROTECTION LAMP ON	Shut down	Turn radio down Wait for AMP to cool
	Speaker wires shorted	Separate speaker wires and insulate

SOUNDSTREAM

SOUNDSTREAM
www.soundstream.com

