

SOUNDSTREAM®

D-Tower Amplifier Series

Owner's Manual

CONGRATULATIONS !

You now own a D-Tower Amplifier, the product of an uncompromising design and engineering philosophy. We suggest you take a moment to document the information below, which will be helpful in the event of theft or if service is needed. Please retain this manual and your sales receipt for future reference.

SOUNDSTREAM amplifiers are the result of American innovation and the highest quality control standards. When properly installed, they will provide you with many years of listening pleasure. Should your amplifier ever need service or replacement due to theft, Please record your information on the following lines to refer to in the event that you may need it later.

Serial# _____

Dealer's Name _____

Date of Purchase _____

Installation Shop _____

Installation Date _____

CAUTION !

Prolonged listening at extremely high levels may result in hearing loss. Even though your new Soundstream D-Tower Amplifier sounds better than anything you've heard, exercise caution to prevent hearing damage .

FEATURES

- THE WORLD'S FIRST VERTICAL CAR AMPLIFIER.
- COMPACT SIZE AND TINY FOOTPRINT.
- SINGLE END CABLE WIRING.
- DOUBLE SIDE PCB AND SMD COMPONENTS.
- FULL MOSFET DESIGN.
- LPF AND SUBSONIC CROSSOVER.
- ADJUSTABLE BASSBOOST FREQUENCY AND LEVEL.
- INFINITELY VARIABLE PHASE CONTROL.
- 1-OHM LOAD STABLE FOR ALL CLASS-D MODELS (EXCEPT FOR LARGEST MODEL WHICH IS .5-OHM LOAD STABLE).
- HEAVY-DUTY ALUMINUM ALLOY HEATSINK.
- HIGH (Speaker) OR LOW (RCA) LEVEL INPUTS.
- OVERLOAD, OVERHEAT, HIGH/LOW VOLTAGE PROTECTION.
- RoHS COMPLIANT.

CONTROL FUNCTIONS

1. SPEAKERS

Connect speakers/subwoofers to these terminals. Be sure to check wire for proper polarity. Never connect the speaker cables to chassis ground.

2. +12 Volt Power

Connect this terminal through a FUSE or CIRCUIT BREAKER to the positive terminal of the vehicle battery or the positive terminal of an isolated audio system battery.

Warning: Always protect this power cable by installing a fuse or circuit breaker of the appropriate size within 18 inches (45cm) of the battery terminal connection.

3. Remote Turn On

This terminal turns on the amplifier when (+)12 volt is applied to it . Connect it to the remote turn on lead of the head unit or signal source.

4. GND

Connect this cable directly to the frame of the vehicle. Make sure the metal frame has been stripped of all paint down to the bare metal. Use the shortest distance possible. It is always a good idea to replace the factory ground at this time with a larger cable equal to the new amplifier power cable or larger. **CAUTION:** Do not connect this terminal directly to the vehicle battery ground terminal or any other factory ground points.

5. RCA input jacks

These RCA input jacks are for use with source units that have RCA outputs. A source unit with a minimum level of 200mV is required for proper operation. The use of high quality twisted pair cables is recommended to decrease the possibility of radiated noise entering the system.

6. High level inputs

The high level inputs are for use with speaker level wiring. Some source units do not have RCA outputs, so use this terminal for speaker level signal input. **CAUTION:** Never use high level input when RCA inputs available.

CONTROL FUNCTIONS

7. REMOTE

Connect the remote controller to control the subwoofer amplifier volume from the driver seat location, for ease of adjustment during playing.

8. LEVEL Control

The level control will match the amplifiers sensitivity to the source units signal voltage. The Operating range is 200mV minimum to 5V maximum. This is NOT a volume control!

9. Low Pass Filter Control

This control is used to select the desired low pass x-over frequency. The frequency can be adjusted from 40Hz to 220Hz for all bass mono models.

10. Subsonic Filter Control

This control can filter out unwanted low frequency from 10Hz (OFF) to 50Hz. This function will increase the power handling of your woofers.

11. Bass Boost Frequency and Level Control

By adjusting these two knobs, you can boost a wanted frequency to a wanted level. The center boost frequency is adjustable from 30Hz to 90Hz, the boost level is adjustable from 0dB to 12dB.

12. Phase Control

This control can adjust speaker output phase from 0 to 180 degrees infinitely to match your system phase characteristics.

13. X-over mode and frequency Control (Full range)

These controls allow control over the frequencies played for the front channels. There is an option for Low Pass, Full Range or High Pass. In LP or HP mode the frequency range is from 50Hz to 4kHz.

CONTROL FUNCTIONS

14. X-over mode and frequency Control (Monoblocks)

These controls allow control over the frequencies played for the rear channels. There is an option for Low/BandPass, Full Range or High Pass. In HP mode, the frequency range is from 15Hz to 500Hz. In LP mode, the frequency range can be switched from 50Hz to 800Hz, or 250Hz to 4kHz. In the higher range, the LPF can be set at 4kHz for a midbass while the front channels are also set at 4kHz for a tweeter resulting in a 2-way xover and eliminating the need for a passive xover. Even with a set up like this, the midbass can still be protected by the HPF which is not defeatable. It can be set anywhere in the 15Hz to 500Hz range creating a bandpass filter for the midbass by eliminating any damaging lower frequencies in the subbass region.

15. Bass Boost Level switch

This switch can boost bass level by 0dB, 6dB or 12dB. The boost frequency is centered at 50Hz.

16. Input mode switch

This function is for switching the rear channels' signal path. When switched to 4CH, all 4 RCAs inputs are required. When switched to 2CH, the rear channels get their signal input from the front channels in parallel.

17. Power Indicator

This LED will light up when amplifier works properly.

18. Protection Indicator

The red LED will light up and will be flashing if there is a fault presented to the amplifier. Please disconnect the amplifier and resolve the fault before reconnecting the amplifier.

INSTALLATION PRECAUTIONS

Before you install the amplifier, investigate your car's layout very carefully. Take special care when you work near the gas tank, fuel lines, hydraulic lines and electrical wiring. Before making or breaking power connections in your system, disconnect the

vehicle battery. Confirm that your head unit or other equipment is turned off while connecting the input jacks and speaker terminals. If you need to replace the power fuse, replace it only with a fuse identical to that suggested by this manual. Using a fuse of a different type or rating may result in damage to your audio system or your amplifier which is not covered by warranty .

MOUNTING AMPLIFIER

1. Soundstream D-Tower amplifiers can be installed vertical or horizontal.
2. Plan the installation method and find a suitable location with sufficient air circulation.
3. Check the drawing below to see how to mount the feet for vertical or horizontal mounting.
4. Be sure to install the amplifier in a way that makes adjustments easy.
4. Make sure that the wiring is secure to avoid damage.

Fig 3. Feet installation

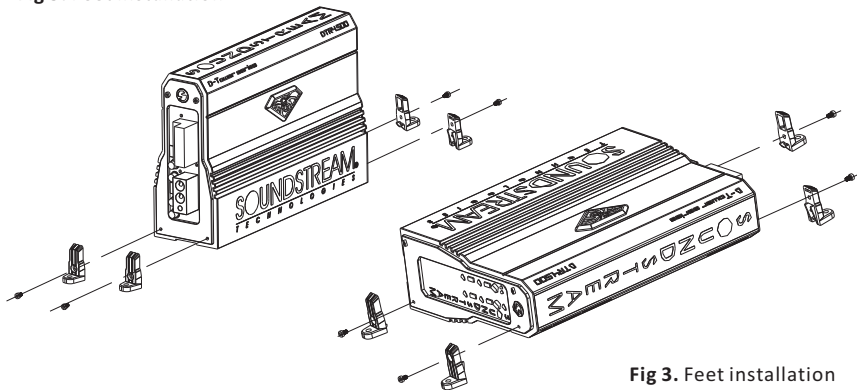
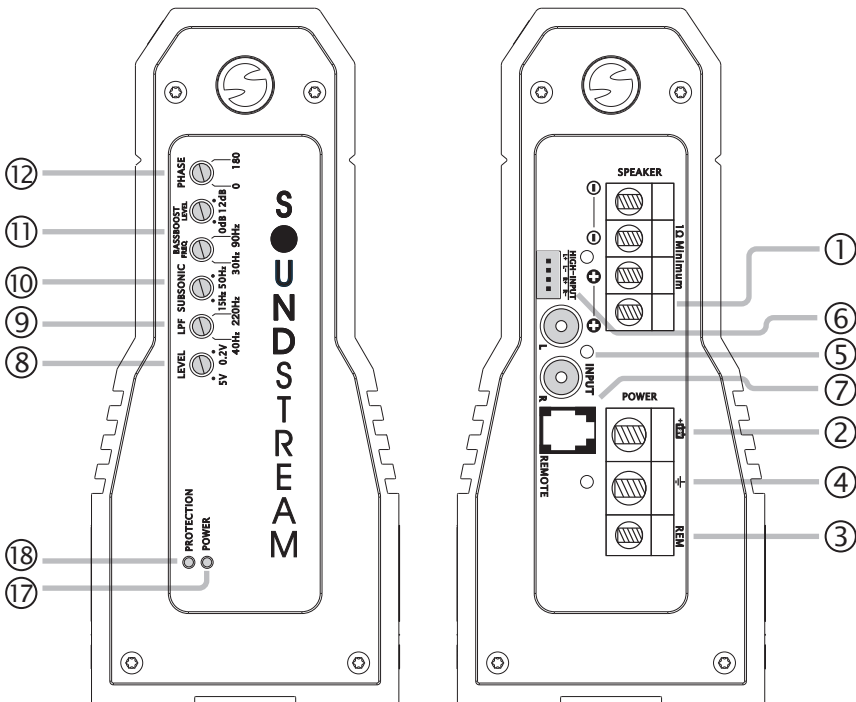

Fig 3. Feet installation

PANEL LAYOUT

Fig 1. Mono amplifier panel layout



DTR1.900D / DTR1.1400.D / DTR1.1700D / DTR1.2200D / DTR1.3400D

PANEL LAYOUT

Fig 2. 4-ch amplifier panel layout

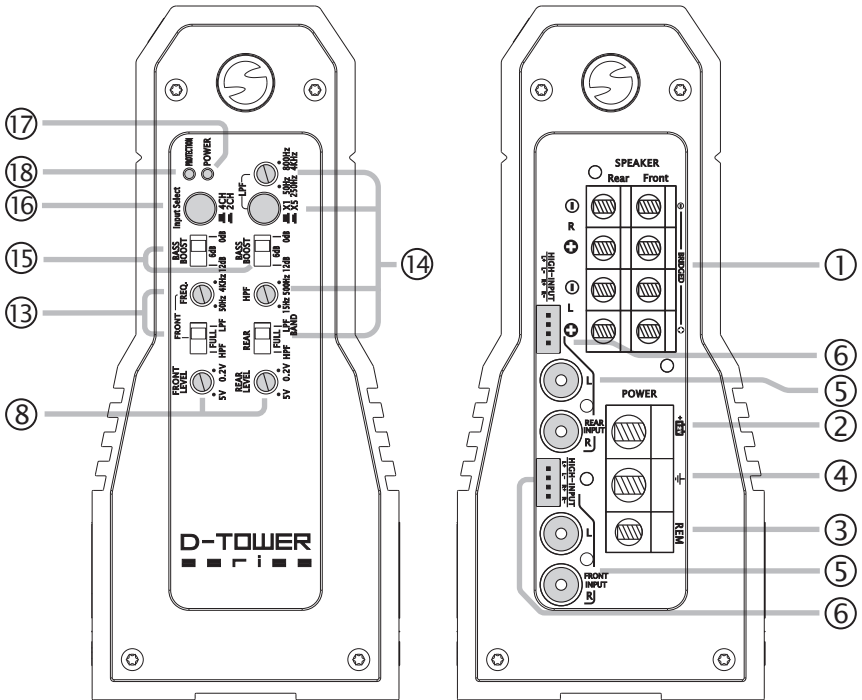

DTR4.500

PANEL
LAYOUT

CONNECTING THE AMPLIFIER

1. Select cable and fuse according to the following table.

MODEL	DTR1.900D	DTR1.1400D	DTR1.1700D	DTR1.2200D	DTR1.3400D	DTR4.500
CABLE	6-4	4	4-2	2-0	0	6-4
FUSE	80A	100A	150A	200A	250A	60A

2. Connect the amplifiers ground cable to a close, bare metal part of the frame or chassis. Use a nut and bolt, NOT a screw! The ground cable must be at least the same size as the +12volt cable.

3. Connect the remote terminal to remote output of the head unit using 16 gauge (or heavier) wire.

4. Connect the fuse holder within 18" (45cm) of the car battery, and run the selected cable from this fuse to the amplifier.

5. Connect all the inputs with high-quality cables. Connect Remote Control if necessary.

6. Insert fuse(s) into the battery fuse holder(s).

7. If using the rear channel of the DTR4.500 for a subwoofer, bridge the channels by using the Left "+" and the Right "-" terminals.

WIRING DIAGRAM

Fig 4. Mono amplifier wiring
(1 woofer load)

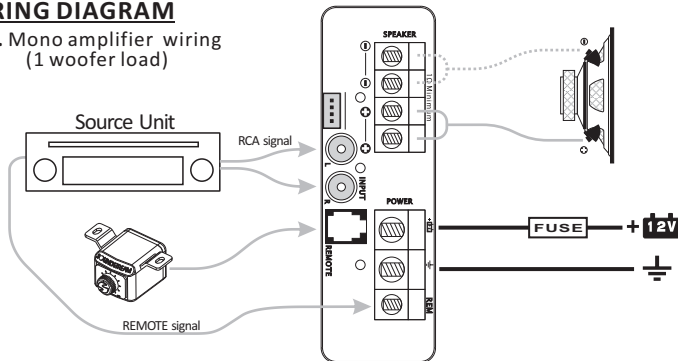

WIRING DIAGRAM

Fig 5. Mono amplifier wiring
(High level input mode)

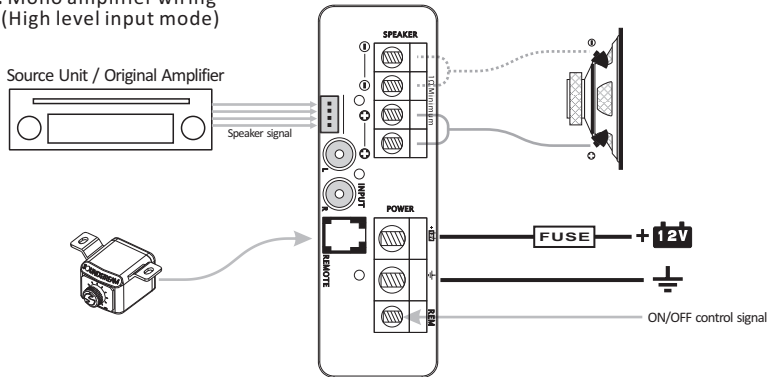
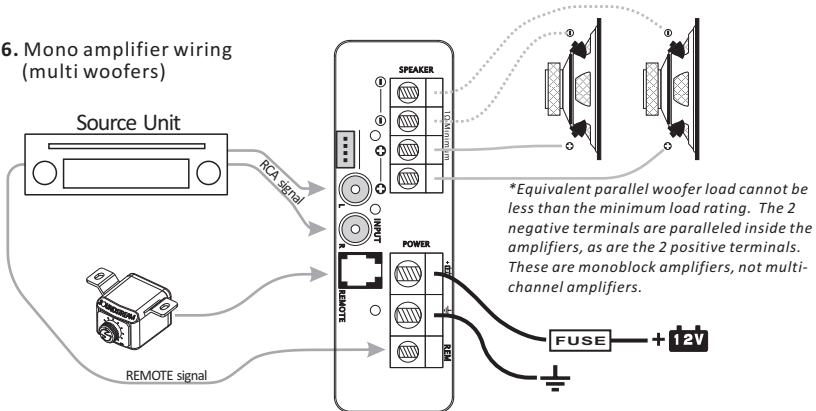

Fig 6. Mono amplifier wiring
(multi woofers)



WIRING DIAGRAM

Fig 7. DTR4.500 wiring
(4-channel mode)

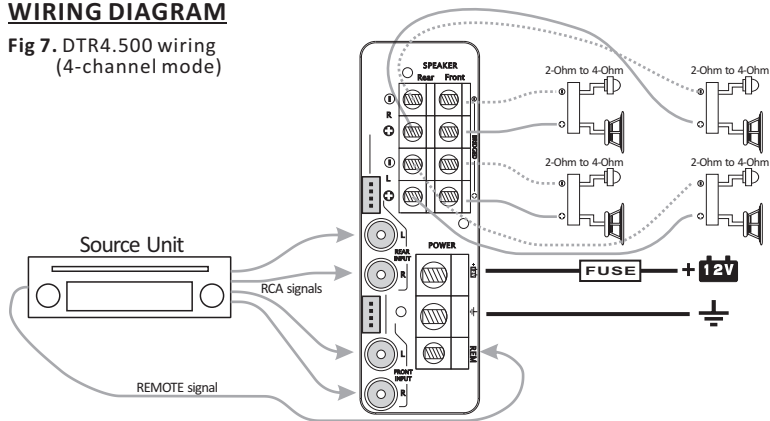
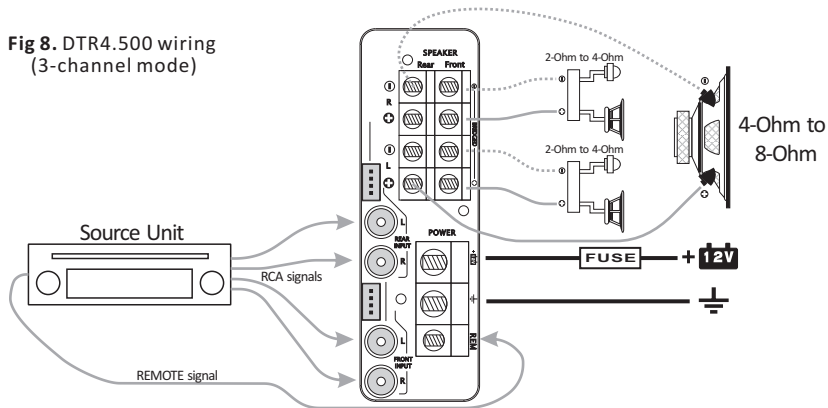

Fig 8. DTR4.500 wiring
(3-channel mode)



WIRING DIAGRAM

Fig 9. DTR4.500 wiring
(active x-over mode)

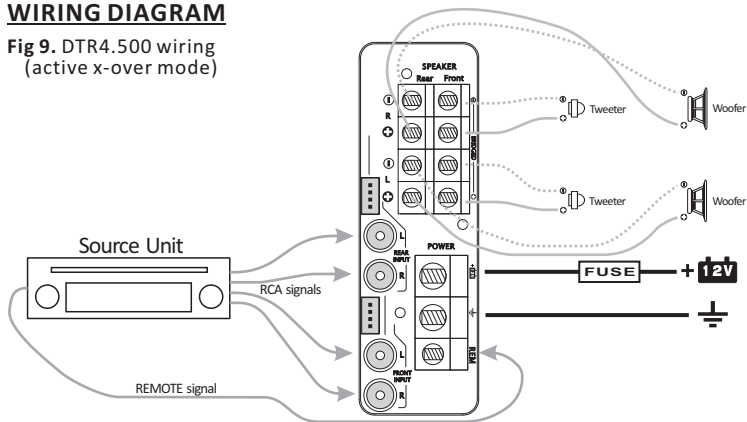
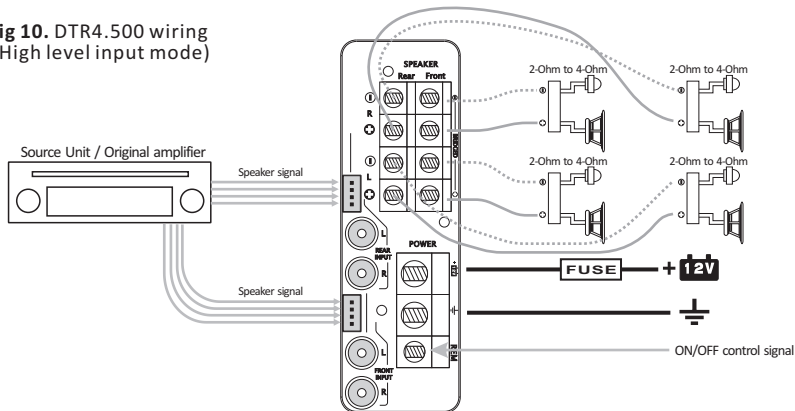

Fig 10. DTR4.500 wiring
(High level input mode)



TROUBLE SHOOTING

Symptom	Possible Remedy
Amplifier will not power up	<i>Check to make sure you have a good ground connection. Check that there is battery power on the (+)terminal . Check all fuses, replace if necessary . Make sure that the Protection LED is not illuminated.</i>
Protection LED Comes on	<i>Check for short circuits on speaker leads. Check the speaker load not beyond the minimum load. Remove speaker lead, and reset the amplifier. If the protection LED still Comes on, then the amplifier is faulty and needs servicing .</i>
No output	<i>Check that the RCA audio cables are plugged into the proper inputs. Check all speakers wiring. Check the headunit output and the amplifier level setting.</i>
Low output	<i>Reset the level Control. Check the Crossover Control settings.</i>
High hiss in The speakers	<i>Check the RCA cable is not shorted to power ground at amplifier side. Check the amplifier grounding.</i>
Distorted sound	<i>Check that the Input level control is set to match the signal level of the head unit. Always try to set the Input level as low as possible. Check that all crossover frequencies are properly set. Check for short circuits on the speaker leads.</i>
Amplifier gets Very hot	<i>Check that the minimum load impedance for the amplifier model is correct. Check that there is good air circulation around the amplifier. In some applications, It may be necessary to add an external cooling fan.</i>

SPECIFICATIONS

Model	DTR1.900	DTR1.1400	DTR1.1700	DTR1.2200	DTR1.3400	DTR4.500
RMS Power at 14.4V						
0.5 Ohm	N/A	N/A	N/A	N/A	3400	N/A
1 Ohm	900	1400	1700	2200	2200	N/A
2 Ohm	600	900	1100	1400	N/A	125
4 Ohm	N/A	N/A	N/A	N/A	N/A	80
Features						
Input Level	0.2V - 5V				0.2V - 5V	
High Level Input	Yes				Yes	
Frequency Response	10Hz - 220Hz				15Hz - 25kHz	
X-over Type	LPF/Subsonic				LPF/Full/HPF	
LPF	40Hz - 220Hz				Front 50Hz - 4kHz Rear 50Hz - 800Hz or 250Hz - 4kHz	
Subsonic / HPF	10Hz - 50Hz				Front 50Hz - 4kHz Rear 15Hz - 500Hz	
Bass Boost Frequency	30Hz - 90Hz				50Hz	
Bass Boost Level	0-12dB				0dB, 6dB, 12dB	
THD	<0.5%				<0.05%	
Damping Factor	>200				>200	
S/N Ratio	>85dB				>100dB	
Phase Shift	0-180				N/A	
Minimum Load	1 Ohm			0.5 Ohm		2 Ohm
Voltage Protection	<8.4V & >16V					
Components & PCB	SMD Parts / Double-Sided FR-4 PCB					
Bass Remote	Yes				N/A	
Dimensions						
Height	190mm / 7.5"				190mm / 7.5"	
Width	84mm / 3.3"				84mm / 3.3"	
Length	291mm 11.46"	296mm 11.65"	371mm 14.61"	401mm 15.79"	451mm 17.75"	291mm / 11.46"

