Precautions

Before you drill or cut any holes, investigate your car's layout very carefully. Take care when you work near the gas tank, fuel lines, hydraulic lines and electrical wiring.

Do not operate the amplifier when it is not mounted. Attach all audio system components securely within the automobile to prevent damage, especially in case of an accident.

Do not mount this amplifier so that the wire connections are unprotected or in a pinched condition, or likely to be damaged by nearby objects.

Before making or breaking power connections in your system, disconnect the vehicle battery. Confirm that your head unit or other equipment is turned off while connecting the input jacks and speaker terminals.

If you need to replace the power fuse, replace it only with a fuse identical to that supplied with the system. Using a fuse of different type or rating may result in damage to your system which isn't covered by the manufacturer's warranty.

SOUNDSTREAM®

T E C H N O L O G I E S

Owner's Manual and Installation Guide

Lilwonder **III** *Generation*

LW1.840D

SPECIFICATIONS:

MODELS	LW1.840D
Channels	1ch. Class D
RMS Power @ 4Ω , 14.4V	-
RMS Power @ 2Ω , 14.4V	680
RMS Power @ 1Ω , 14.4V	950
Total Harmonic Distortion (4Ω power)	0.50%
Frequency Response	15-150Hz
Signal-to-Noise Ratio (4Ω power)	>61
Damping Factor (100Hz, 4Ω)	>300
Signal Voltage	100mV-2V or 2V-8V
Fusing	(3) 35
Dimensions:(2"h x 8"w)	13.375"
12dB/octave Low Pass Filter	50-150Hz
Remote Gain Control	Included
Bass Boost	0-18dB @ 40Hz
Subsonic Filter (12dB/octave)	24dB, 15-40Hz
Phase Control	180°

CLASS-D MONOBLOCK AMPLIFIER LW1.840D

FEATURES:

- One Ohm Stable MonoBlock amplifier
- MOSFET Power Supply
- PWM (Pulse Width Modulation) System
- Glass/epoxy Printed Circuit Board
- Nickel-plated RCA Input and Bypass Output jacks
- Nickel-plated Speaker and Power Terminals
- Protection Circuitry Against Thermal, Overload and Short Circuit Faults
- Input Sensitivity Selector
- Variable Subsonic Filter (15Hz-40Hz, 24dB/octave)
- Variable Low Pass Filter (50Hz-150Hz, 24dB/octave)
- 0/180° Phase Selector
- Remote Subwoofer Level Control

LW1.840D Front

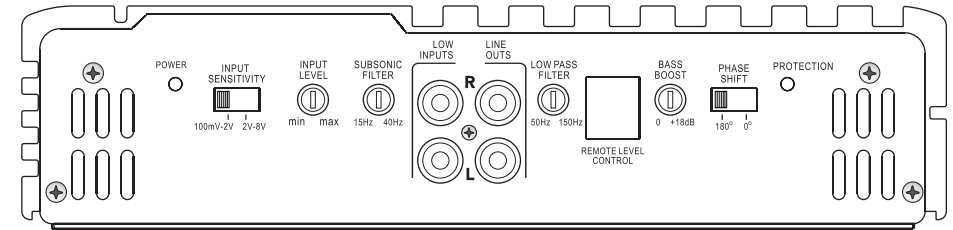

LW1.840D Rear

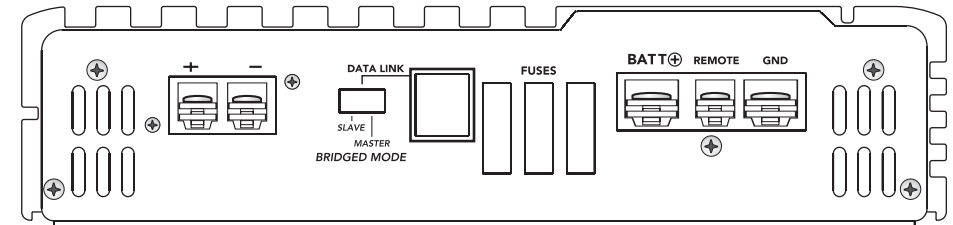

Installation

Important Installation Considerations and Precautions

The design philosophy of this amplifier requires strict adherence to proper installation and load impedance instructions. The minimum recommended impedance is 2 Ohms.

The fuse rating for the LW1.840D is 105 amperes (3 x 35A fuses). Although sufficient for normal working conditions, overloading of the amplifier may cause these fuses to blow. Please try to avoid overloading the amp in this manner.

- 1 Mount the amplifier so that air flow is not restricted.
- 2 Mount the amplifier to a solid surface, as these amplifiers are extremely heavy.
- 3 Take extreme caution when mounting the amplifier, so as not to damage the chassis with a drill or screwdriver.
- 4 Run a 4 gauge wire from the battery, using a fuse within 18" (457mm) of the positive battery terminal. The purpose of this wire is to protect the battery in the event that this wire accidentally contacts the chassis ground on its run to the amplifier.
- 5 Place the fuse holder near the amplifier on the 12V POSITIVE lead.
- 6 Run a 4 gauge wire (as short as possible) to the closest chassis ground point. Be sure to remove the paint at the connection to the chassis of the vehicle for a good electrical connection.
- 7 Run a 16 gauge (or larger) wire to the remote turn-on lead of the head unit.
- 8 Connect the speaker(s) as per the wiring diagrams in this manual.
- 9 Using RCA interconnect cables, connect all line inputs and outputs per the wiring diagrams which follow if possible, keep the RCA cords away from the 12V power and Ground wiring.
- 10 Set the controls as described in the following sections of this manual.

While these amplifiers are designed to operate with a minimum load of 1 Ohm, it is highly recommended that you design your system to operate with 2 Ohms minimum impedance. Operating a Lil' Wonder digital amp with a speaker impedance load of under 1 Ohm may result in poor sound quality and serious damage to the amplifier circuitry. Damage to your amplifier caused by operating with a load of less than 1 Ohm is not covered under the warranty for this product.

Front Panel Connections

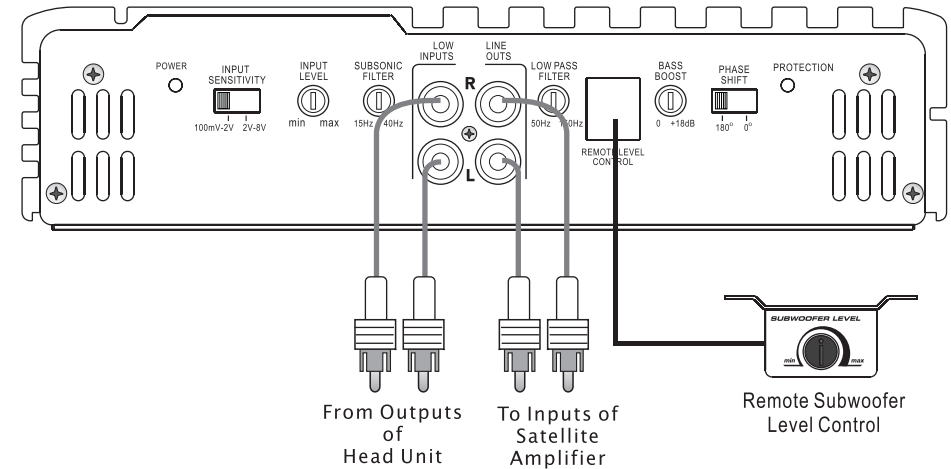

Rear Panel Connections

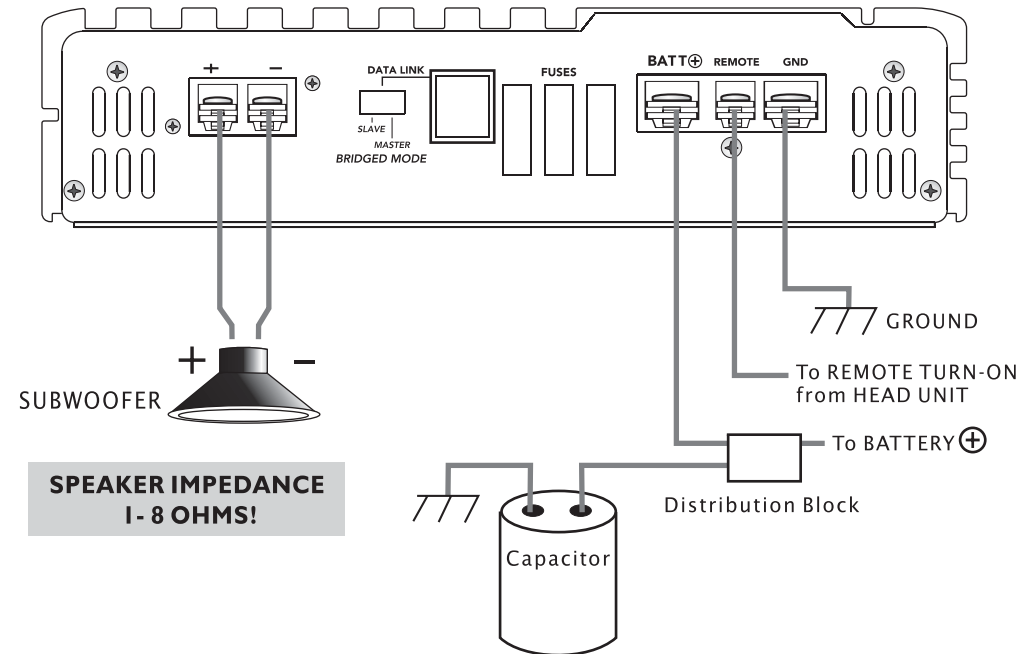

NOTE: The amplifier may receive its input signal from a head unit or signal processors subwoofer output.

Bridging Two Amplifiers

LW1.840D

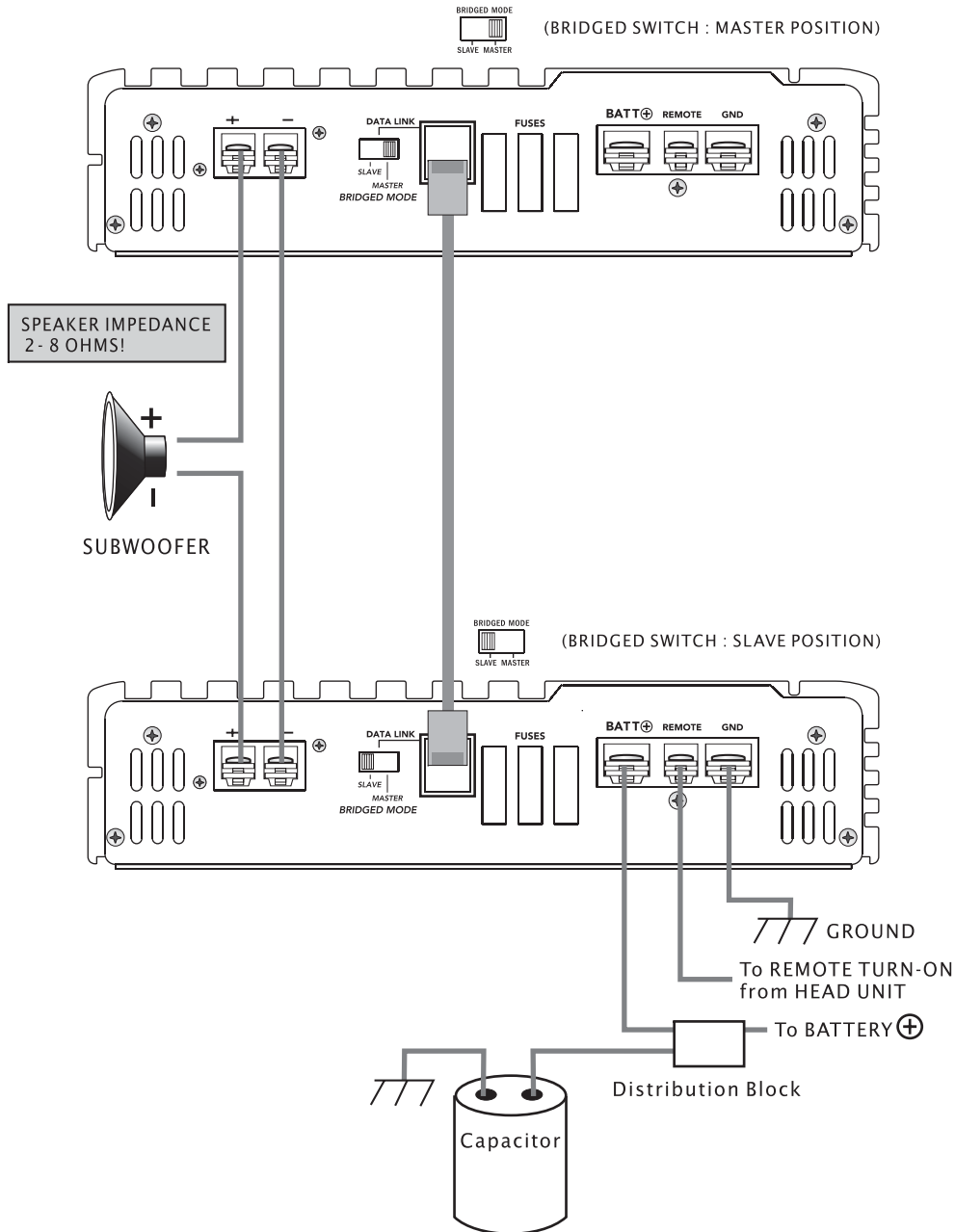

Electrical Wiring

The LW3G LW1.840D power amplifier is equipped with easy top access screw terminals. These terminals are nickel-plated in order to ensure excellent electrical contact and to resist corrosion.

When making electrical connections to the amplifier, please observe the following:

- Use at least 8 gauge or heavier wire for power and ground connections.
- Wire the amplifier directly to the car battery. Make sure there is circuit protection (Such as a fuse) on the positive power lead, within 18 inches of the battery.
- For the ground connection, use the shortest possible wire to a good chassis ground point.
- Wire the Remote connection to the remote turn-on lead of your equalizer or head unit. In some cases this may be the power antenna lead of the head unit.

Remote Subwoofer Level Control

The LW3G LW1.840D power amplifiers are equipped with a dashboard mount remote subwoofer level control. Run the supplied dashboard remote control from the front panel of your amplifier. By turning the level knob clockwise, you will increase the output of low frequencies.

Fuses

Fuses protect both the amplifier and the electrical system of your vehicle from faulty conditions. If you must replace the fuse in your amplifier, use a fuse of exactly the same type and rating. A different type or rating may result in damage or cause a fire.

Mounting the Amplifier

Mark the location for the mounting screw holes by positioning the amplifier where you wish to install it and use a scribe (or one of the mounting screws) inserted in each mounting hole to mark the mounting surface. If the mounting surface is carpeted, measure the hole centers and mark with a felt tip pen.

Drill pilot holes in the mounting surface for the mounting screws and insert the mounting screws into these holes. Tighten them securely.

Note: Before beginning your installation, be sure to take note of any wires, lines or other devices in your vehicle which may be located behind any mounting surface.