

---

# **SOUNDSTREAM**

**EXC/.4**

**EXC/.5**

**EXC/.6**

## Component Speaker System **OWNER'S MANUAL**

**SOUNDSTREAM**  
TECHNOLOGIES

---

# Component Speaker System

## INTRODUCTION AND REGISTRATION

Congratulations on your purchase of the Soundstream EXC Component Speaker System. You now own one of the finest car audio speaker systems available.

As with all high quality car audio components, professional installation is recommended. Your dealer's knowledge and experience can ensure a problem-free, cosmetically integrated installation. If you plan on installing the EXC speaker system yourself, please review this Owner's Manual first before attempting installation. In addition, it's a good idea to keep the manual for future reference.

EXC Woofer Serial Number \_\_\_\_\_

Date of Purchase Date of Installation \_\_\_\_\_

Dealer's Name \_\_\_\_\_

## HARDWARE AND CONNECTOR PARTS LIST

Before beginning your installation, please check to see that the number of parts contained in your box match the list below:

### Hardware

- 2 each - flush-mount cups
- 12 each - 1 1/4" #8 sheet metal screws (for mounting EXC woofers)
- 2 each - 1/4" 6-32 machine screws (for tweeter flush mount cup spring clips)
- 4 each - stainless steel tweeter spring clips (for tweeter flush mount cup)
- 4 each - 1/2" flat head screws (for tweeter surface mounting)
- 1 each - template set

### Connectors

- 4 each - 1/4" tab female gold insulated slip-on connectors (for EXC woofers)
- 16 each - gold spade connectors (for connecting to crossover)
- 4 each - 1/8" gold round female connectors (for connecting tweeter to speaker wire)
- 4 each - vinyl insulators (for insulating tweeter speaker connectors)

## EXC DESIGN

The EXC Component Speaker System is the result of highly focused engineering effort. Each element of the EXC system represents several advances in automotive speaker technology. When the EXC project was initiated, the following goals were established:

- High performance sound reproduction in the automotive environment.
- Ease of installation
- Superb ergonomics and visual appeal.
- High output capability
- Ability to "tailor" sound to each vehicle

Through extensive testing and development, the EXC system has been designed to provide extremely consistent on and off-axis response in the automobile. Installation flexibility and ergonomics are enhanced by the mounting versatility of both the EXC midrange/woofer and the EXC tweeter. Finally, the high output capability and low frequency extension of the EXC woofers are atypical of most drivers due to the excursion capabilities of the EXC woofers and the steep crossover slopes of the EXC system crossovers.

These efforts have resulted in an extremely flexible speaker system that performs flawlessly in a variety of locations.

## FEATURES

### EXC Midrange / Woofer

The EXC woofers represent a departure from typical midrange/mid-bass drivers by combining massive mid-bass *and* exceptionally smooth midrange.

- Non-resonant Glass resin basket has been designed specifically for extra long excursion. This results in higher output and extended low frequency response.
- Non-resonant cone geometry yields smooth response and ultra-low distortion.

### EXC Soft Dome Neodymium Tweeter

The EXC tweeter is an ultra-high performance 1" Neodymium tweeter designed to deliver outstanding high frequency reproduction

- **Fourth-generation Neodymium Magnetic Assembly** providing performance comparable or superior to tweeters three times the size
- **A newly improved Textile Dome** for a natural, smooth response to 20 kHz.
- **Ferrofluid-immersed Voice Coil** enhances heat dissipation

### EXC Passive Crossover Network

The EXC Passive Crossover represents a new concept in crossover philosophy. The EXC system crossover consists of high quality, multi-element components with two switchable functions. A three-position switch controls the tweeter level and a two-position switch controls the midrange presence. The combination of each allows for a multitude of control options. Dual inputs allow for multi-channel amp operation of woofer and tweeter circuits.

- **24 dB/octave Acoustic Summation Crossover Slopes** for smooth response.
- **Variable Tweeter and Midrange Controls** for added flexibility.
- **Dual Inputs** for multi-amp operation and further flexibility.
- **Dynamic Tweeter level Control** allows for improved power handling and continuous output.
- **Ultra-low DCR Inductors** for minimal signal loss (High power Air-core type in woofer path).
- **Mylar Film Capacitors** to ensure low saturation and accuracy in the high frequencies.

## LOCATION AND MOUNTING

The first step in a successful installation is thorough planning. Choose the location for your speaker components carefully. Follow these suggestions to ensure proper imaging and the best performance:

- Select a location where each tweeter and midrange/woofer can be mounted close to each other. A good rule of thumb is a maximum of one foot from midrange/woofer to tweeter.
- Choose a location that offers the least amount of sound obstruction.
- Try to mount the components on the same plane.
- Always check behind the chosen mounting locations to make sure that there are no obstructions (e.g., trunk springs, gas tank, window track) or wires in the way, as well as to make sure that there is ample support on which to mount the components.

## INSTALLING THE EXC TWEETER

The EXC tweeter can be installed in a variety of ways: a simple yet elegant installation cup is provided for flush mounting; or the tweeter may be easily disassembled for custom applications, such as installation in vents, custom painting, or mounting behind a factory grille. Hardware is provided for each mounting configuration.

For surface mounting, locate a flat mounting surface for the EXC tweeter. A direct "on-axis" location is not necessary, as the EXC tweeter provides extraordinary "off-axis" response.

### Flush Mounting

- 1) Cut a 1 7/8" diameter hole through the mounting surface. If the surface is covered with cloth or carpet, be careful not to tear or pull the material. Sometimes it is a good idea to peel the material away and then trim it by hand.
- 2) Secure the cup in the mounting cutout by using the spring clips and screw provided. Slip the spring clips through the bottom of the cup and tighten the screw until the cup is firmly seated. See Figure 1.
- 3) Once the cup is secure, mount the tweeter into the cup making sure to pass the tweeter wires through the openings in the cup. The tweeter will lock into the cup when turned clockwise. See Figure 2.

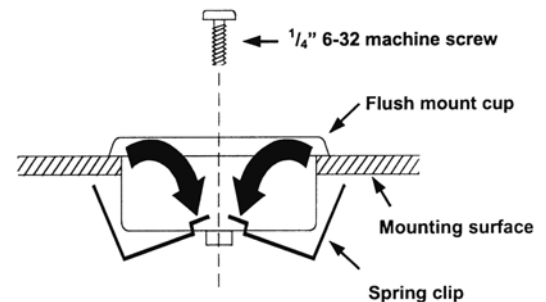

FIGURE 1

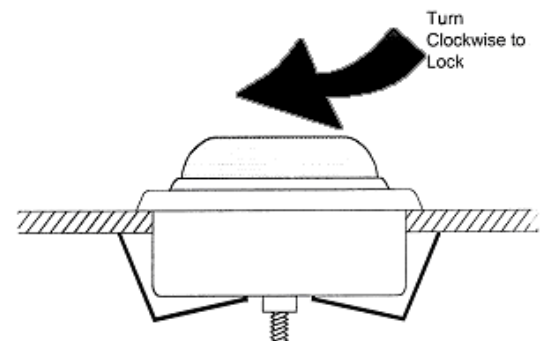

FIGURE 2

## TWEETER SURFACE MOUNTING

- 1) Remove the tweeter's plastic backplate by separating the plate from the tweeter housing with your two thumbnails at one of the terminal locations, gently prying the two pieces until they snap apart. See Figure 3.
- 2) Mark the location in which you are going to mount the tweeter using the supplied template and drill holes for each of the two wires. Also drill small "pilot" holes for the two mounting screws.
- 3) Mount the backplate with the two 1/2" flat head screws. See Figure 4 below.
- 4) Feed the wires through the holes and attach them to the speaker wires going to the crossover. Position the tweeter over the backplate and then simply snap it back on. Be sure to feed the Red wire through the (+) marked hole.

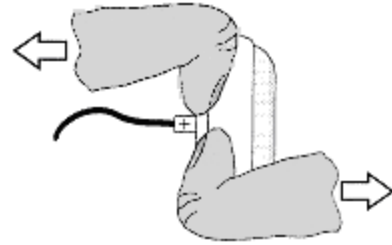

FIGURE 3

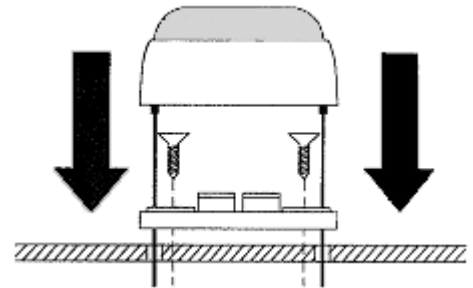

FIGURE 4

## TWEETER ANGLE MOUNTING

- 1) Remove and discard the tweeter's plastic backplate as described above.
- 2) Drill out the appropriate holes in the back of the angle mount. Mark the location in which you are going to mount the tweeter using the supplied template and drill holes for each of the two wires. Also drill small "pilot" holes for the two mounting screws.
- 3) Mount the angle mount backplate with the two 1/2" flat head screws. See Figure 5.
- 4) Feed the wires through the holes and attach them to the speaker wires going to the crossover. Position the tweeter over the backplate and then simply snap it back on.

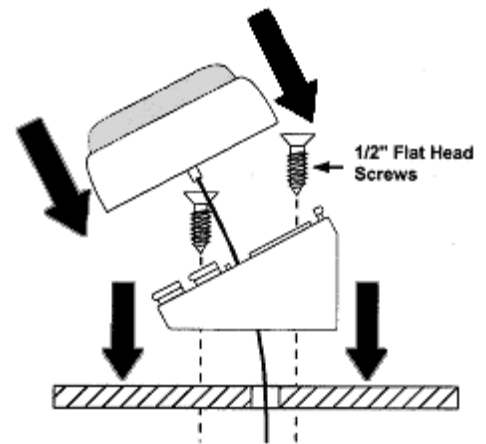
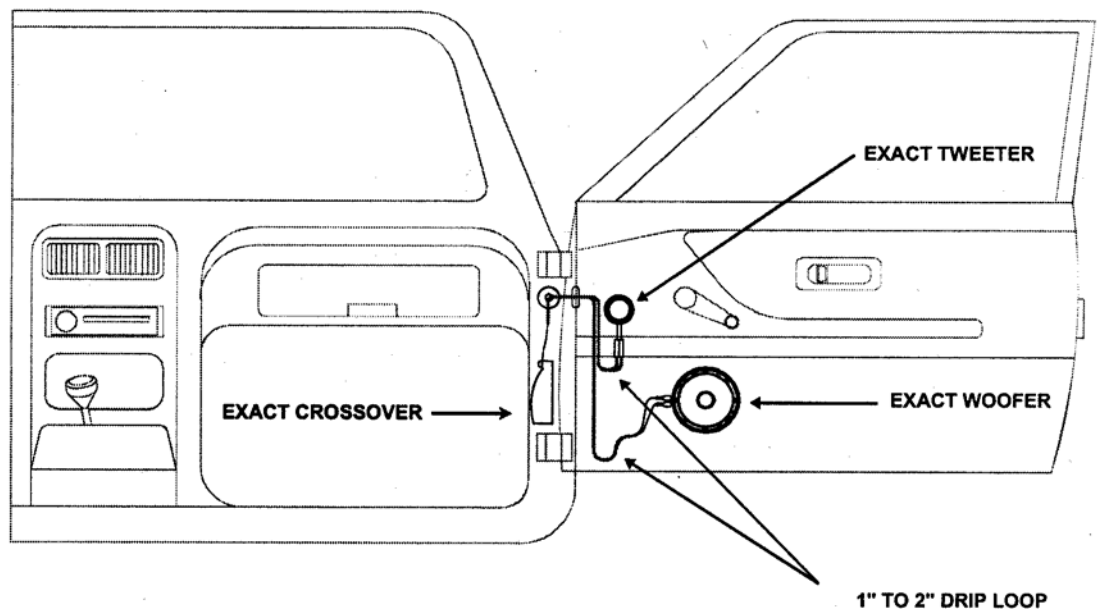

FIGURE 5

## INSTALLING THE EXC MIDRANGE- WOOFER

The EXC Midrange/Woofer can be mounted on the front or rear of a panel; gaskets are provided for both options. The bolt-hole configuration will fit a variety of standard OEM patterns making it ideal for direct replacement. Best performance is achieved when the speaker is securely mounted to a door panel or rear deck. There should be no gaps between the speaker and the mounting surface, as this will impair its low frequency performance. Be certain that both the panel and the speaker are securely mounted to prevent unwanted vibration.

1. Mark the speaker location by using the template provided.
2. Cut the opening and debur the edges with a file.
3. Hold the speaker in place against the mounting surface and mark the mounting bolt holes.
4. Drill the appropriate size pilot holes for the screws provided.
5. Make all speaker connections prior to mounting the speaker to the panel.
6. Place the Exact woofer into the trim ring, make the speaker wire connections, then install the speaker/trim ring assembly to the panel using the screws provided. Affix the grille.
7. When routing speaker cables to the driver, it is important to form a drip loop in the cable below the level of the driver to keep water from reaching it. See Figure 6.



**MOUNTING THE EXC CROSSOVER**

The EXC Passive Crossover can be mounted in virtually any location inside the vehicle. Be sure not to mount the EXC system crossover outside the vehicle, or in a location where it may be exposed to dirt or moisture (e.g., the engine compartment, inside a wheel housing, inside a door, at the bottom of a leaky trunk).

**TWEETER LEVEL CONTROL**

**Tweeter Attenuation**

The EXC system has been designed to provide optimum sound in a variety of installation locations. The provided crossover allows for three positions of tweeter level control: HIGH, MED and LOW. The LOW position is useful for using the EXC system in rear-fill applications. A switch under the clear plastic crossover cover sets one of the three positions. See Figure 7.

**MIDRANGE LEVEL CONTROL**

**Midrange Attenuation**

The provided crossover also allows for two positions of midrange level control. A switch under the clear plastic crossover cover sets one of the two positions - MIDRANGE PRESENCE -- ON/OFF. The ON position provides increased midrange, a feature useful for adjusting midrange vocal presence. See Figure 7.

**DYNAMIC TWEETER LEVEL CONTROL**

**Tweeter Protection Activation**

Under high power/high volume conditions, the dynamic tweeter level control (DTLC) circuit may activate. The purpose of DTLC is to prevent failure of the tweeter by reducing its output when necessary. Upon activation of the DTLC circuit, there will be an audible decrease in high frequency output as well as a visual indication from the DTLC light bulb (see Figure 7). The circuit is self-resetting -- if the DTLC activates, turn the volume down and normal operation will resume momentarily.

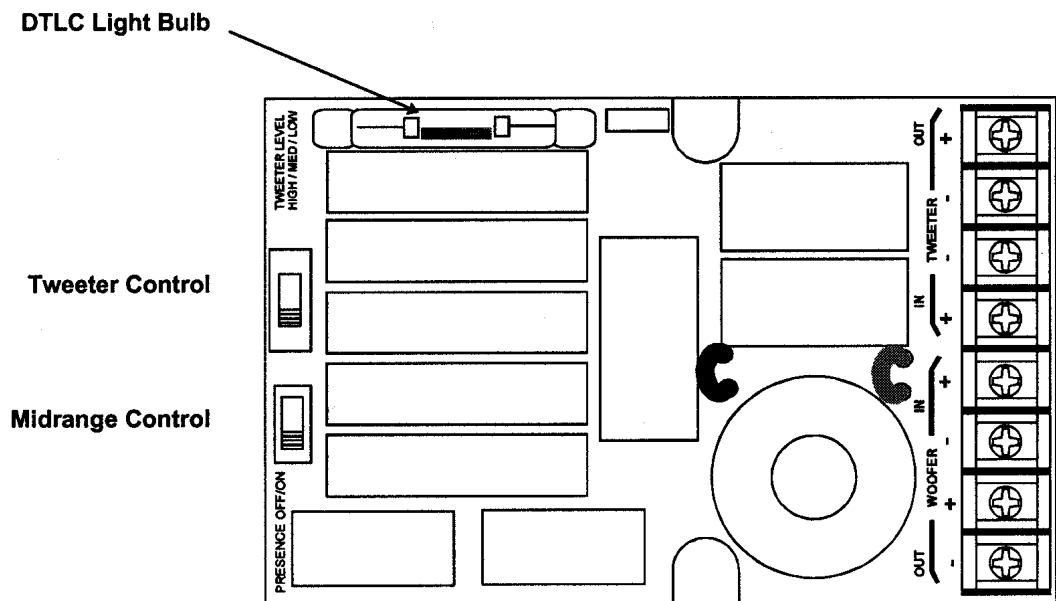
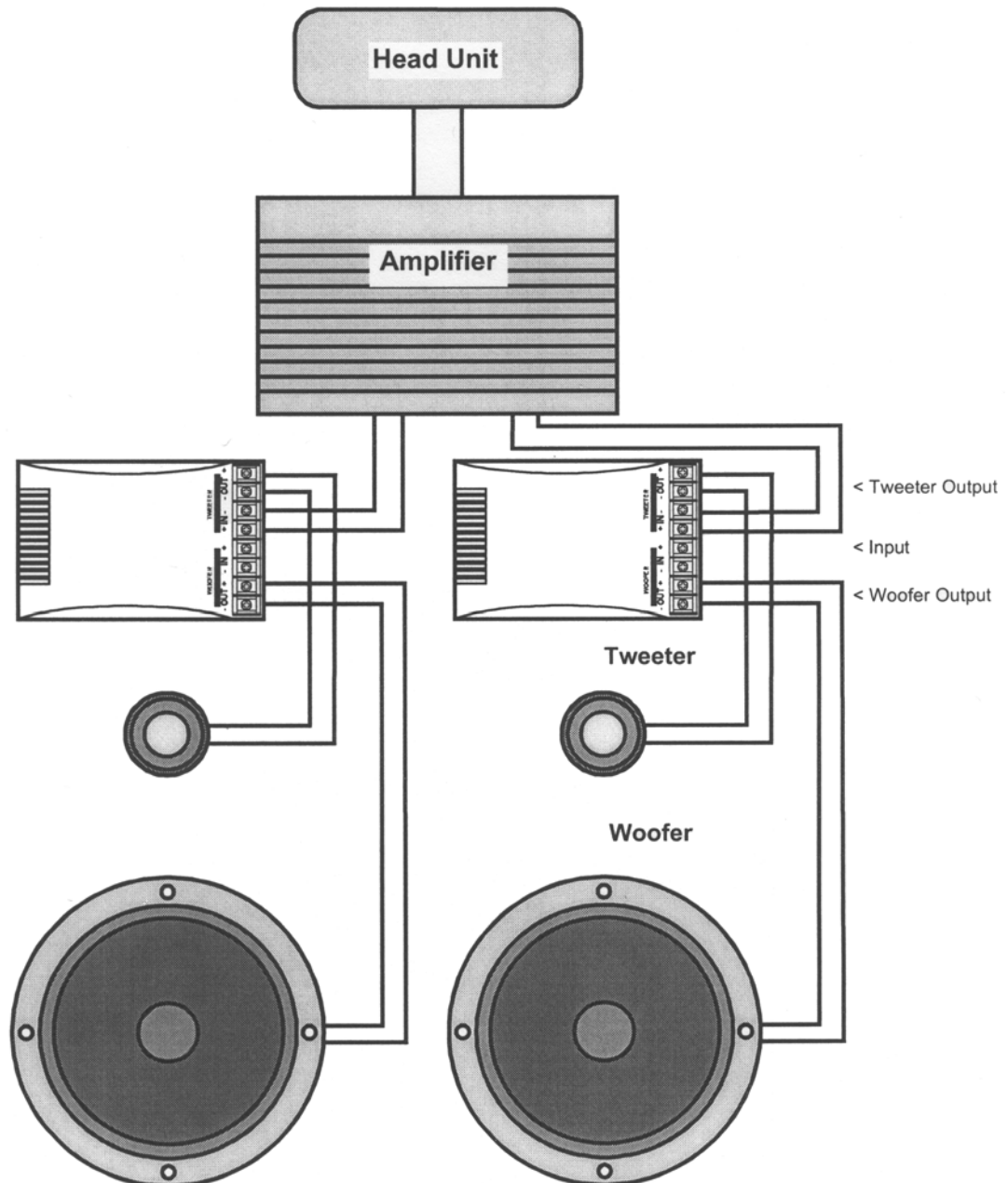

FIGURE 7

## WIRING

### EXC System Wiring Diagram

Figure 8 shows a diagram illustrating the wiring of the EXC Component Speaker System. It is important to make sure that all connections are in phase; that is positive (+) is connected to positive (+), and negative (-) is connected to negative (-), since an out-of-phase connection will cause a dislocated image and low bass output. We suggest using a minimum of 16 gauge (ideally 12 gauge) premium cable. The connectors provided with this system will accommodate wire from 12 gauge to 16 gauge.





### NOTES ON BI-AMPING

#### Bi-Wiring

The EXC component system includes the EXC passive crossover which is optimized for the speakers. The EXC crossover allows for dual amp inputs. See Figure 9.

This feature allows for a 4 channel amplifier or two 2 channel amplifiers to power the four individual drivers of an EXC .6 system. The benefit of this is added dynamics and level setting flexibility. A head unit's fader control could be used as a tweeter level control. (See note about crossover modification for bi-amping.)

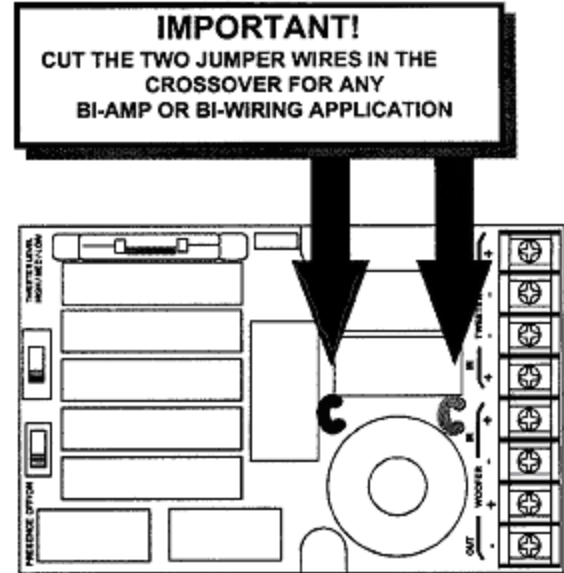
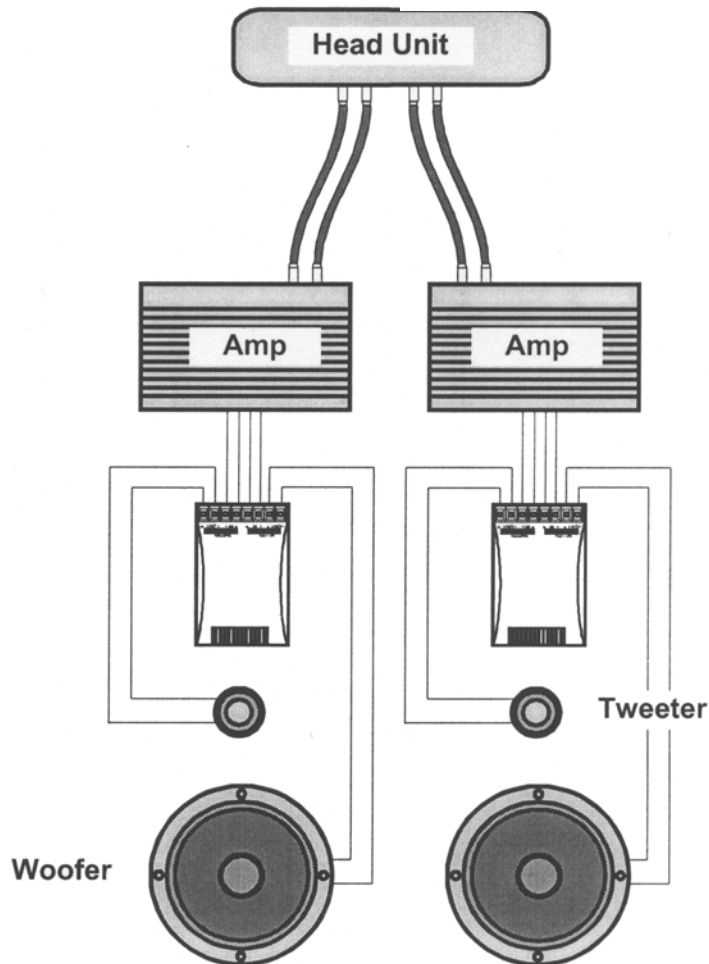

Figure 9



**NOTES ON BI-AMPING (CONTD.)**

**Bi-Amping**

True bi-amping can also be accomplished with an external electronic crossover. See Figure 10. Even greater dynamics can be realized with bandwidth-limited amplifiers. If you decide to bi-amp, please follow the recommendations below:

- 1) Use at least a 12dB/octave high pass filter no higher than 1500 Hz on the tweeters.
- 2) Use at least a 12dB/octave low pass filter no lower than 6000 Hz on the woofers.

This "staggered" active arrangement allows one full octave of bandwidth between the amp's active range and the speaker's passive range. This stagger allows the purpose designed passive network to operate as intended. You will gain the benefit of dedicated amplifiers and retain the sound quality designed into the passive crossover.

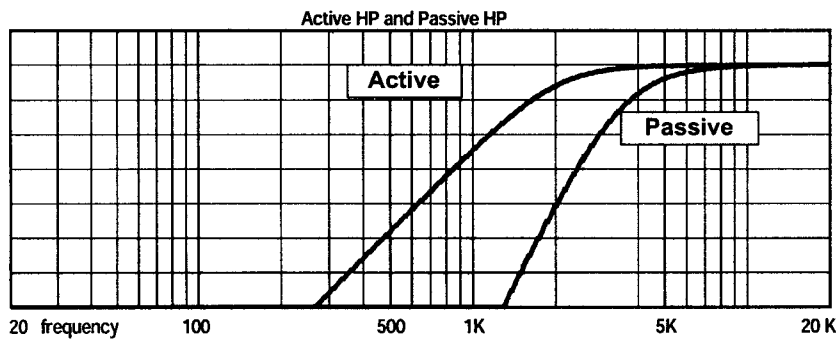
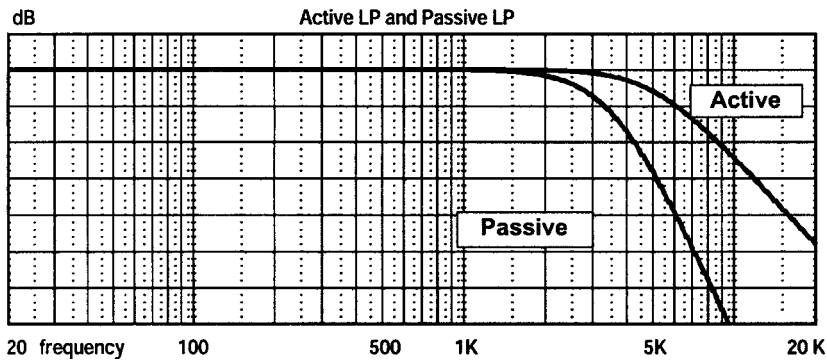
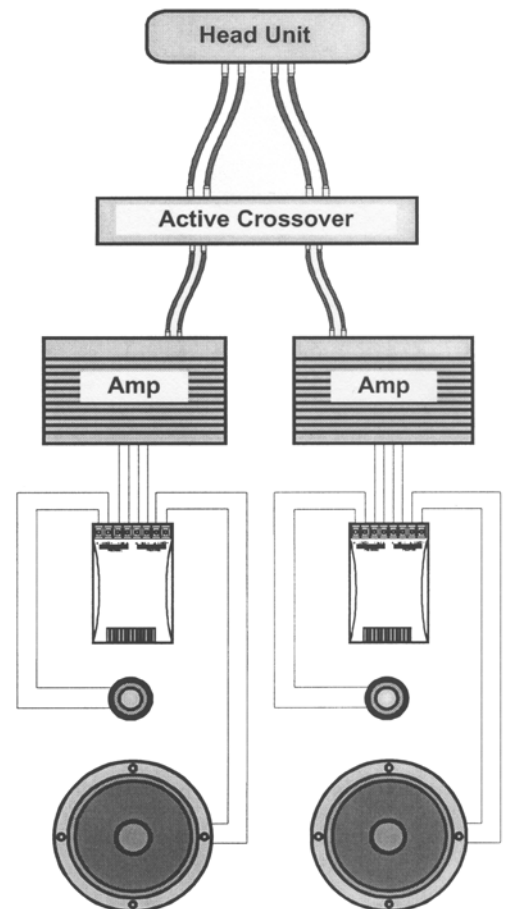

Figure 10 Active/Passive Bi-Amp



## SPECIFICATIONS

### EXC System Specifications

	<b>EXC/.4</b>	<b>EXC/.5</b>	<b>EXC/.6</b>
Frequency Response	70 Hz - 20,000 Hz +/-3dB	60 Hz - 20,000 Hz +/-3dB	50 Hz - 20,000 Hz +/-3dB
Sensitivity	90 dB SPL at 1 meter (2.83v) 96 dB SPL at .5 meter (2.83v)	91 dB SPL at 1 meter (2.83v) 97 dB SPL at .5 meter (2.83v)	92 dB SPL at 1 meter (2.83v) 98 dB SPL at .5 meter (2.83v)
Continuous Power Handling	60 watts	70 watts	80 watts
Peak Program Power Handling	120 watts	140 watts	160 watts
Nominal Impedance	3Ω	3Ω	3Ω
Crossover Slope Rate	24 dB/octave ASC	24 dB/octave ASC	24 dB/octave ASC
Crossover Dimensions	3.25" (W) x 15" (H) x 5.125" (D)	3.25" (W) x 15" (H) x 5.125" (D)	3.25" (W) x 15" (H) x 5.125" (D)

### EXC Midrange/Woofer

Frequency Response	70 Hz - 7,000 Hz +/-3dB	60 Hz - 7,000 Hz +/-3dB	50 Hz - 7,000 Hz +/-3dB
Continuous Power Handling	60 watts with EXC .4 Crossover	70 watts with EXC .5 Crossover	80 watts with EXC .6 Crossover
Peak Program Power Handling	120 watts with EXC .4 Crossover	140 watts with EXC .5 Crossover	160 watts with EXC .6 Crossover
Sensitivity	90 dB SPL at 1 meter (2.83v)	91 dB SPL at 1 meter (2.83v)	92 dB SPL at 1 meter (2.83v)
Nominal Impedance	3Ω	3Ω	3Ω
Nominal Driver Diameter	4 1/4"	5 1/4"	6 1/2"
Mounting Cut-Out Diameter	3 9/16"	4 13/16"	5 3/4"
Mounting Depth	2 1/8"	2 1/4"	2 11/16"

### EXC Soft Dome Neodymium Tweeter

Frequency Response	2,500 Hz - 20,000 Hz +/-3dB
Sensitivity	92 dB SPL at 1 meter (2.83v)
Nominal Impedance	4Ω
Nominal Tweeter Diameter	1"
Mounting Cut-Out Diameter	1 7/8"

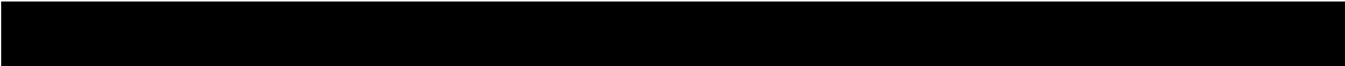

**SOUNDSTREAM<sup>®</sup>**

T E C H N O L O G I E S

1550 Maple Ave., Montebello, CA 90640 USA  
Phone: (323)724-4600 Fax: (323)722-8125  
[www.soundstream.com](http://www.soundstream.com)

