



# Owner's Manual

**Digital Class D2  
Extreme Bass Machine**

**Di175.1 Di300.1  
Di360.4 Di475.1**

## INTRODUCTION

Amplifiers provide high-performance sound reinforcement for your mobile audio equipment. Its versatility enables compatibility with optional Equalizers, Frequency Dividing Network Crossovers, and other audio processors in a customized system. The Multi-Mode bridging Capabilities allow flexibility in hosting several different speaker configurations.

To achieve optimum performance, it is highly recommended that you read this Owner's Manual before beginning installation.

## FEATURES

- PWM Power Supply
- 3 Stage Protection Circuit
- SMD Technology
- MIL-Spec Fiberglass Circuit Board
- True Digital Switching
- High Rail Voltage
- 2 Ohm Stable
- Compact Chassis
- Full MOSFET Circuitry
- High Level Input
- Line Output
- Bass Boost @45Hz +6 dB or +12 dB(Sub woofer Amplifier)
- 18 dB Crossover Centered at 80 Hz(Sub woofer Amplifier)
- Selectable HPF/LPF @ 80Hz crossover(Full Range Amplifier)

## WARNING

High powered audio systems in a vehicle are capable of generating "Live Concert" high levels of sound pressure. Continual exposure to excessively high volume sound levels may cause hearing loss or damage. Also, operation of a motor vehicle while listening to audio equipments at high volume levels may impair your ability to hear external sounds such as; horns, warning signals, or emergency vehicles, thus constituting to a potential traffic hazard. In the interest of safety, Consumer Electronics recommends listening at lower volume levels While driving.

## TABLE OF CONTENTS

PLANNING YOUR SYSTEM .....	4
MOUNTING YOUR AMPLIFIER .....	4
WIRING CONNECTION .....	5-7
POWER INDICATOR LED .....	7
INPUT SENSITIVITY CONTROL .....	7-8
CONNECTING THE SPEAKER .....	8-10
TROUBLE SHOOTING GUIDE .....	11
WARNING .....	12
SPECIFICATION .....	12

## PLANNING YOUR SYSTEM

Before beginning the installation, consider the following:

- If you plan to expand your system by adding other components sometime in the future, ensure adequate space is left, and cooling requirements are met.
- Speaker level or RCA, which to use and why?  
If your source unit is equipped with both types of outputs, Use the RCA's for the amplifier inputs, as this provides for increased bandwidth and you can still utilize the speaker Outputs, for driving the (smaller) front speakers directly.

**NOTE:**

**DISTORTION LEVEL IS CONSIDERABLY LOWER FROM PRE-AMP(LOW LEVEL) OUTPUTS, THAN SPEAKER (HIGH LEVEL)OUTPUTS.**

- Are your components matched? The peak power rating of your speakers must be equal or greater than the Amplifier's. They also must be 2-8 Ohms impedance(This information is normally printed on the speaker magnet).
- Consider both the length of your leads, and routing when determining the mounting location. Pre-Amp input Jacks require a length of high quality shielded male to male RCA patch cord.

## MOUNTING YOUR AMPLIFIER

The mounting position of your Amplifier will have a great effect on its ability to dissipate the heat generated during normal operation. It has an ample heat sink for heat dissipation, and it is also designed with a thermal shut-down(for heat protection)circuit, making air to be directed over the cooling fins will improve heat dissipation dramatically. DO NOT enclose the amplifier in a small box or cover it so that air cannot flow around fins.

Temperatures in car trunks have been measured as high as 175°F(80°C)in the summer time. Since the thermal shut-down point for the Amplifier in 185°F(85°C)it is easy to see that it must be mounted for maximum cooling capability. To achieve maximum advantage of convection air flow in an enclosed trunk, mount the amplifier in a vertical position, on a vertical surface.

Cooling requirements are considerably relaxed when mounting inside the passenger compartment since the driver will not often allow temperatures to reach a critical point. Floor mounting under the seat is usually satisfactory as long as there is at least 1 inch(2cm) above the Amplifier's fins for ventilation.

- Select a suitable location that is convenient for mounting, is accessible for wiring, and has an ample room for air circulation and cooling.
- Use the amplifier as a template to mark the mounting holes. Remove the Amplifier and drill 4 holes. With extreme caution, inspect underneath surface before drilling.
- Secure the Amplifier using the screws provided.

## WIRING CONNECTIONS

### A. CONNECTING THE POWER

**CAUTION:**  
AS A PRECAUTION, IT IS ADVISABLE TO DISCONNECT THE VEHICLE'S BATTERY BEFORE MAKING CONNECTION TO THE +12 VOLTS SUPPLY WIRING.

4/8 GAUGE (Or thicker if planning for additional Amplifiers) wire is recommended for both the power and ground wires. 12 Gauge, for the remote turn wire. Both types are available at most Mobile Audio Dealers or Installation Shops.

#### (1)GROUND: To Vehicle Chassis

To avoid unwanted ignition noise caused by ground loops, it is essential that the Amplifier be grounded to a clean, bare, metal surface of the vehicles chassis.

**NOTE:**  
GROUND WIRE SHOULD NOT BE EXTENDED MORE THAN 3 FT. (1 METER).

#### (2)+12Volt (Fused) Constant Power: To Battery (+)

Due to the power requirements of the Amplifier, this connection should be made directly to the positive (+) terminal of battery. For safety measure, install an in-line Fuse Holder (not included) as close to the battery positive (+) terminal as possible with an ampere rating: not to exceed total value of fuses in Amp.

Di360.4: 25A x 2  
Di175.1: 25A  
Di300.1: 40A  
Di475.1: 25A x 2

#### (3)Remote Turn-On Input: To Power Antenna output of Car Stereo

This Amplifier is turned "ON" remotely when the vehicle's stereo is turned "ON".

**NOTE:**  
IF YOUR SOURCE UNIT DOES NOT HAVE AN ACTIVE +12 VOLT LEAD WHEN IT IS TURNED-ON, YOU CAN EITHER INSTALL AN AUXILIARY SWITCH, OR YOU CAN TAP-INTO AN IGNITION LEAD; NOTE HOWEVER, THAT YOUR AMPLIFIER WOULD TURN-ON, EVERY TIME YOU START YOUR CAR IF YOU CHOSE THE IGNITION OPTION.

### Di360.4/Di175.1/Di300.1/Di475.1

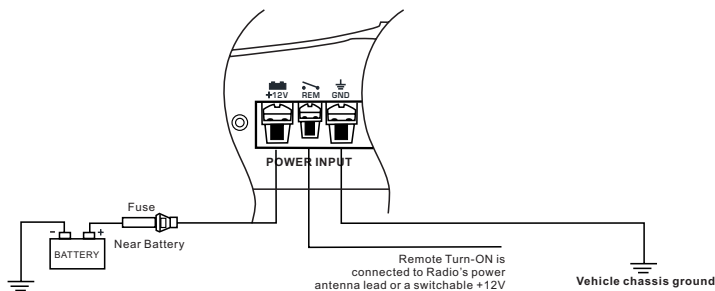

### B. BASS BOOST

By using the bass boost function the deepest bass notes at 50Hz are emphasized.

### C. CONNECTING HIGH LEVEL INPUTS

**NOTE:**  
**DO NOT CONNECT THESE HIGH LEVEL INPUT WIRES IF YOU ARE USING THE LOW LEVEL INPUT RCA JACKS.**  
**CAUTION**  
**NOTE THAT ONLY POSITIVE (+) WIRES ARE USED. DO NOT CONNECT SPEAKER NEGATIVES.**

### Di175.1/Di300.1/Di475.1

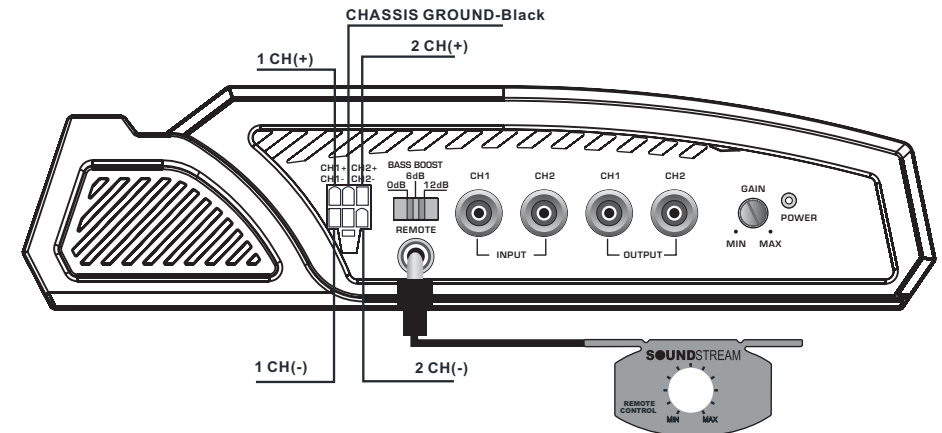

### Di360.4

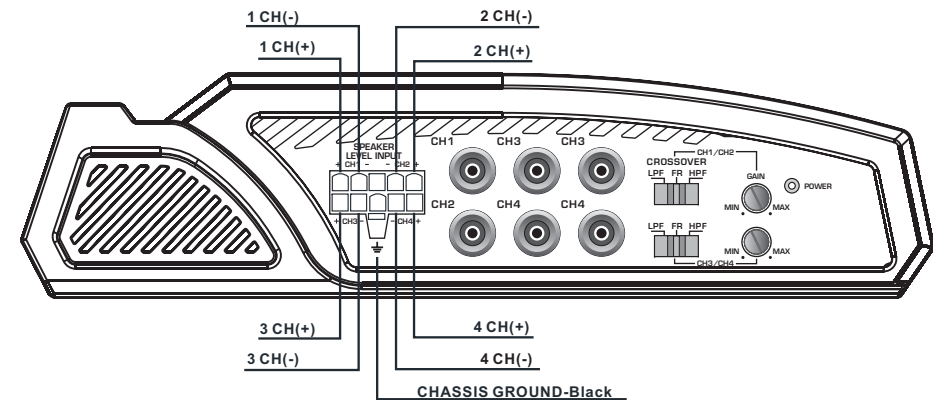

## F. CONNECTING LOW LEVEL INPUTS (RCA Jacks)

NOTE:  
DO NOT USE IN CONJUNCTION WITH HIGH LEVEL INPUT WIRES.

Wire routing is CRITICAL for NOISE FREE PERFORMANCE, Observe the following:

1. Always use high quality RCA type shielded cables.
2. Always use the shortest length possible. If the cable is too long, make an "S" type loop (not a coiled loop) in the center of the cable to take up any excess.
3. Never cut the shielded cable and re-splice it.
4. Never route any Amplifier input cables near nor parallel to speaker outputs, high energy ignition wires, nor near computer controlled ignition circuit units (Computer units may be found behind or under the dash panel in late model cars).

## POWER INDICATOR LED

This METER LAMP will illuminate when the amplifier is turned "ON". If it fails to illuminate, check the power connections to the Amplifier and fuses.

## PROTECTION CIRCUIT

Should the Amplifier be "SHORT CIRCUITED" overloaded or overheated, the protection circuit will "SHUT-DOWN" the Amplifier.

### CAUTION

THIS AMPLIFIER WAS DESIGNED TO BE USED WITH EITHER 2 OHM STEREO/CHANNEL OR 4 OHM EACH MONO BRIDGED CHANNEL. IN THE CASE OF TRI-MODE OPERATION, USE EITHER 8 OHM STEREO CHANNEL SPEAKERS AND 4 OHM SUB OR VICE VERSA. SEE THE SECTION "TRI-MODE" FOR FURTHER INFORMATION ON PROPER USE.

## INPUT SENSITIVITY(LEVEL) CONTROL

In order to achieve maximum signal-to-noise performance, this control adjusts the signal level from your Car Stereo/Source, to match the Amplifier sensitivity. It is NOT a volume control.

### To adjust, proceed as follows:

- a. Set INPUT LEVEL Control at mid-point.
- b. Listen for audible distortion as you increase the Car Stereo VOLUME control. If none is heard, turn the adjustment level control toward to "MAX" in stages, until the onset of audible distortion is heard, then decrease to "MIN" level prior to the immediate point of audible distortion.
- c. If distortion is immediately heard, turn control to "MIN" until the sound is clear.

NOTE:  
NOT PERFORMING ABOVE ADJUSTMENT PROCEDURE AND/OR SIMPLY SETTING THIS CONTROL AT OR NEAR "MAX" POSITION, MAY INDUCE ELECTRICAL AUDIO NOISE INTO THE SYSTEM.

## Di360.4

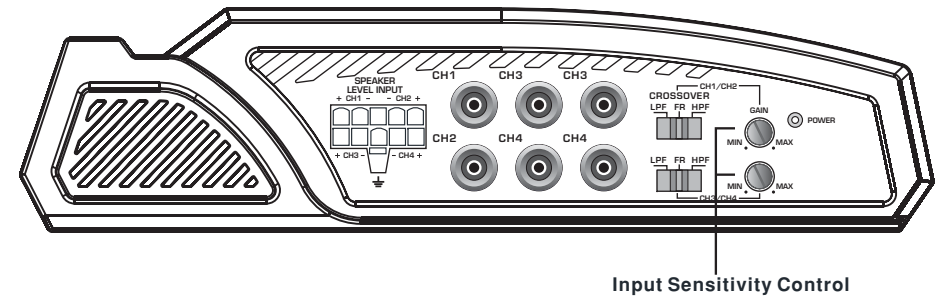

Input Sensitivity Control

## Di175.1/Di300.1/Di475.1

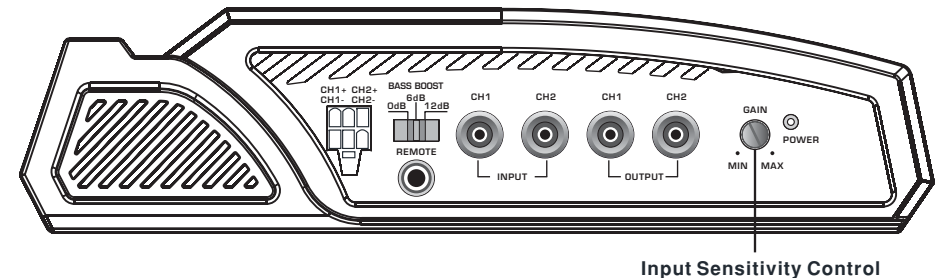

Input Sensitivity Control

## CONNECTING THE SPEAKERS

### Di175.1/Di300.1/Di475.1

#### (A) DUAL MONO MODE

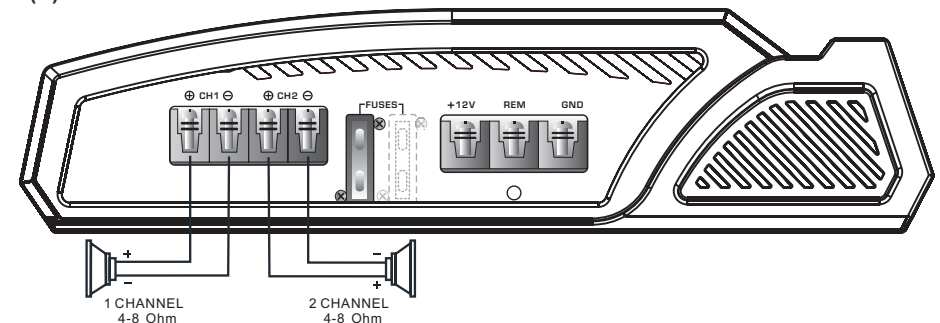

**(B) SINGLE MONO MODE**

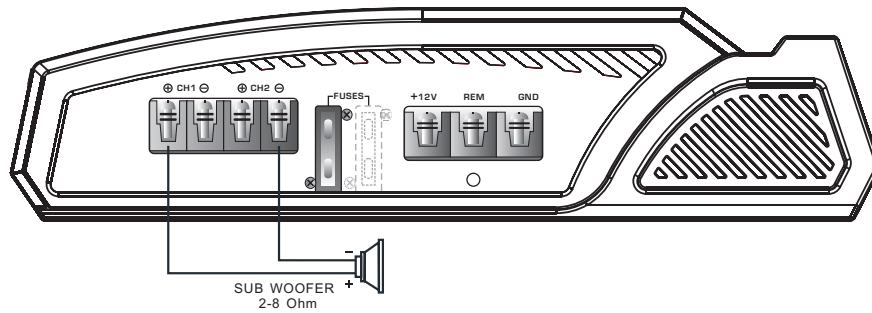

**(C) TRI MODE**

TRI MODE OPERATIONAL OUTPUT allows a Crossover (Subwoofer) to be operated in MONO mode while the main speaker is playing in stereo. Leave the Crossover (Subwoofer) Switch on "FULL" position. Use a 100Volt, non-polar capacitor for a high pass crossover and a wire coil (inductor) to block high frequencies from the Crossover (Subwoofer) as shown in the figure below. Capacitor and inductor values as written in the below determine the crossover frequencies. The front and rear channels of this amplifier get this capability. Only the rear left and right channels are shown below.

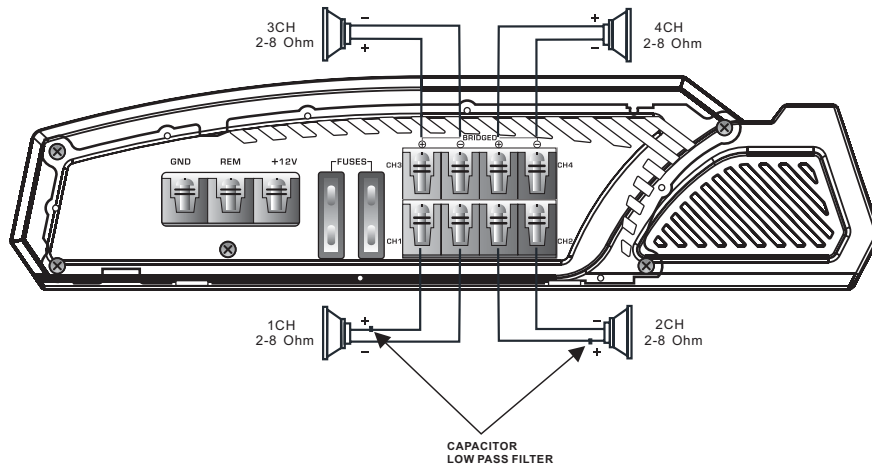

**COMPONENT VALUES FOR 6dB PASSIVE CROSSOVER**

FREQUENCY	INDUCTOR	CAPACITOR
80Hz	7.5mH	470uF
100Hz	6.5mH	330uF
120Hz	5.5mH	330uF
150Hz	4mH	220uF

**Di360.4**

**(A) 4 CHANNEL MODE**

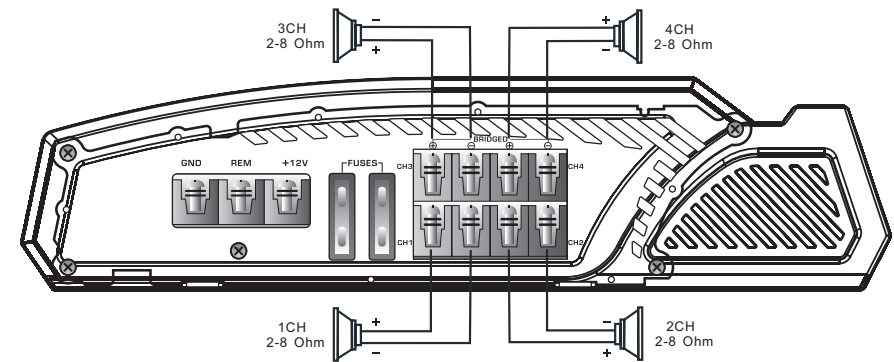

**(B) 4 CHANNEL BRIDGED MODE**

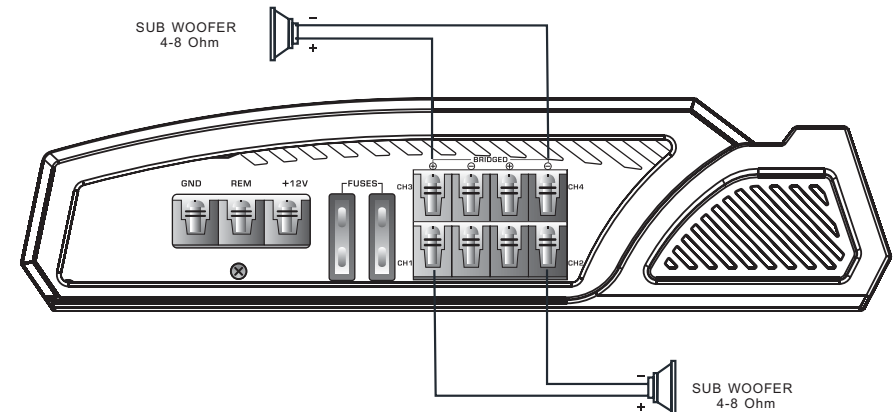

## TROUBLE SHOOTING GUIDE

SYMPTOMS	CHECK POINTS	CURE
NO SOUND	In the power LED illuminated?	Check fuses in amplifier. Be sure Turn-on lead is connected Check signal leads. Check gain control. Check Tuner/Deck volume level. Clean contacts on fuse holders.
	Is the Diagnosis LED illuminated?	Check for speaker short or amplifier overheating.
AMP NOT SWITCHING ON	No power to power wire	Repair power wire or connections.
	No power to remote wire with receiver on	Check connections to radio.
	Fuse broken	Check fuse
NO SOUND IN ONE CHANNEL	Check Speaker Leads	Inspect for short circuit or an open connection.
	Check Audio Leads	Reverse Left and Right RCA inputs to determine if it is occurring before the amp.
AMP TURNING OFF MEDIUM/HIGH VOLUME	Check Speaker load impedance	Be sure proper speaker load impedance recommendations are observed.  (If you use an ohmmeter to check speaker resistance, please remember that DC resistance and AC impedance may not be the same. )
PROTECTION LED ON (RED)	Temperature shutdown	Turn radio down
	Speaker wires short circuit	Separate speaker wires and insulate

## WARNING

Investigate the Layout of you automobile thoroughly before drilling or cutting any holes. Take care when you work near the thanks, lines, or hydraulic lines, and electrical wiring. Don't mount this system so that the wire connections ate unprotected are subject to pinching or damage from nearby objects.

The +12V DC power wire must be fused at the battery positive terminal connection. Before making or breaking power connections at this system power terminals, disconnect the +12V wire at the battery end.

Cofirm your radio/cassette player and/or other equip is turned off while connecting the input jacks and speaker terminals.

If yiu need to replace the power fuse, replace it only with a fuse identical to that supplied with the system. Using a fuse of differcnt type ot rating may result in damage to this system which isn't covered by the warranty.

## SPECIFICATIONS

MODEL NO	Di360.4	Di175.1	Di300.1	Di475.1
CH	4CH	1CH	1CH	1CH
RMS @4 Ohm	45W x 4	125WX1	200WX1	350WX1
RMS @2 Ohm	60W x 4	175WX1	300WX1	475WX1
T.H.D	0.5%	0.5%	0.5%	0.5%
S/N Ratio	98dB	98dB	98dB	98dB
Frequency Response ( 1dB)	20Hz-20KHz	50Hz-150Hz	50Hz-150Hz	50Hz-150Hz
Fuse	25A x 2	25A	40A	25A x 2
Dimension(inches)	10.9x8.7x2.1"	7.2x8.7x2.1"	8. 0x8.7x2.1"	11. 7x8.7x2.1"
BASS Knob	No	Yes	Yes	Yes

FEATURES AND SPECIFICATIONS ARE SUBJECT TO CHANGE WITHOUT NOTICE.

**SOUNDSTREAM TECHNOLOGIES**  
WWW.SOUNDSTREAM.COM