

## PARALLEL/SERIES WIRING DIAGRAMS

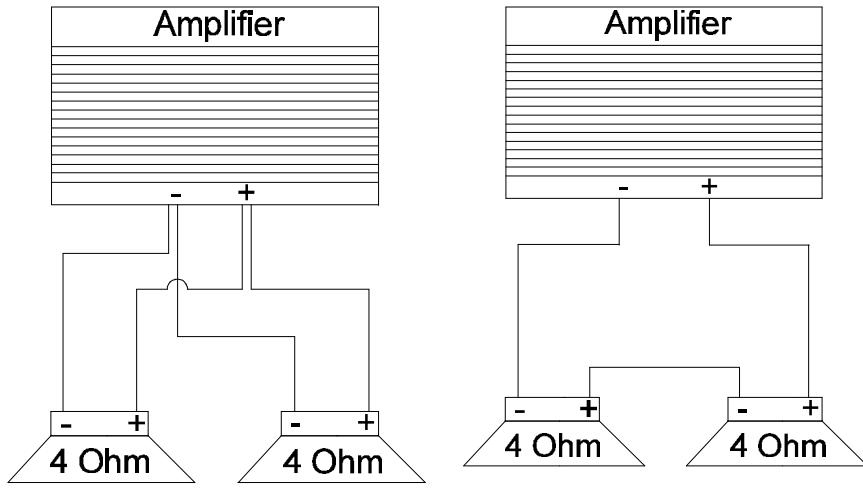

*two 4 ohm woofers  
in parallel = **2 ohms***

*two 4 ohm woofers  
in series = **8 ohms***



**SOUNDSTREAM**<sup>®</sup>  
U \* S \* A

**USA•204**

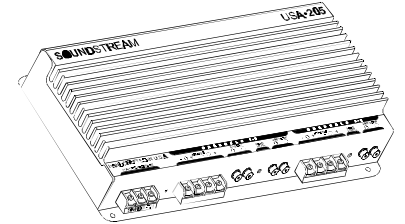

**&**

**USA•364**

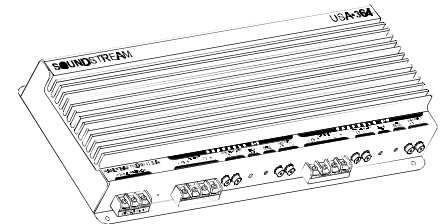

**SOUNDSTREAM**<sup>®</sup>

T E C H N O L O G I E S

SOUNDSTREAM TECHNOLOGIES

120 Blue Ravine Road Folsom California 95630 USA  
ph 916.351.1288 fax 916.351.0414 ver. 1.17.96a

**Power Amplifiers**

**OWNERS MANUAL AND  
INSTALLATION GUIDE**

## **CONGRATULATIONS!**

You now own a Soundstream Amplifier, the result of a unique design and engineering philosophy.

To maximize the performance of your system, we recommend that you thoroughly acquaint yourself with its capabilities and features. Please retain this manual and your sales and installation receipts for future reference.

Soundstream amplifiers are the result of American craftsmanship and the highest quality control standards. When properly installed, they will provide you with many years of listening pleasure. Please record the following information which will help protect your investment should your amplifier ever need replacement or service.

Serial # \_\_\_\_\_

Dealer's Name \_\_\_\_\_

Date of Purchase \_\_\_\_\_

Installation Shop \_\_\_\_\_

Installation Date \_\_\_\_\_

### **CAUTION!**

*Prolonged listening at high levels may result in hearing loss. Even though your new Soundstream amplifier sounds better than anything you've ever heard, exercise caution to prevent hearing damage.*

## **SERVICE**

Your Soundstream amplifier is protected by a limited warranty. Please read the enclosed warranty card.

## **SPECIFICATIONS**

### **POWER OUTPUT**

	<b><i>Stereo Power 4 ohms</i></b>	<b><i>Stereo Power 2 ohms</i></b>	<b><i>Bridged Power 4 ohms</i></b>
<b>USA•204</b>	40w x 4	60w x 4	<b>100w x 2</b>
<b>USA•364</b>	60w x 4	90w x 4	<b>180w x 2</b>

THD	< 0.1%
Signal to Noise	> 90 dB
Frequency Response	20 Hz to 20 kHz +/- 0.5 dB
Stereo Separation	> 90 dB
Damping	> 200
Input Sensitivity	100 mV - 2.5 V
Input Impedance	12 k ohms

### **CROSSOVER SPECIFICATIONS**

High Pass: 12 dB/octave, factory set at 150 Hz  
Low Pass: 12 dB/octave, factory set at 75 Hz

### **DIMENSIONS**

USA•204: 10-1/8" W x 8-3/16" D x 2-3/16" H  
USA•364: 13-1/8" W x 8-3/16" D x 2-3/16" H

## PROTECTION CIRCUITRY

Your USA amplifier is protected against both overheating and short circuits by means of the following circuits:

- Main power supply fuses.
- Speaker output circuit breakers.
- A fail-safe thermal protection circuit activating at 95°C.

**NOTE:** If you experience blown main power supply fuses, DO NOT increase values beyond the original values! Doing so will void your warranty and may damage your amplifier.

## TROUBLESHOOTING

<b>PROBLEM</b>	<b>CAUSE</b>
No sound and LED is not lit	<ul style="list-style-type: none"> <li>• no power or ground at amp</li> <li>• no remote turn-on signal</li> <li>• blown fuse near battery</li> <li>• blown amp power supply fuse</li> </ul>
Repeatedly blown amp fuse, frequent activation of Thermal Protection Circuit	<ul style="list-style-type: none"> <li>• check speaker configuration—impedance may be less than 2 ohms stereo or 4 ohms mono</li> <li>• speaker or leads may be shorted</li> <li>• verify adequate amplifier ventilation</li> </ul>

## TABLE OF CONTENTS

USA•204 Diagram .....	4 - 5
USA•364 Diagram .....	6 - 7
Features .....	8
Crossover Modes .....	9
Crossover Adjustments .....	10
Selecting Input Modes .....	11
Wiring & Wiring Diagram .....	12 - 13
Installation and Mounting .....	14
Level Setting .....	15
Sample Systems .....	16 - 25
Protection Circuitry & Troubleshooting .....	26
Service .....	27
Specifications .....	27

USA•204

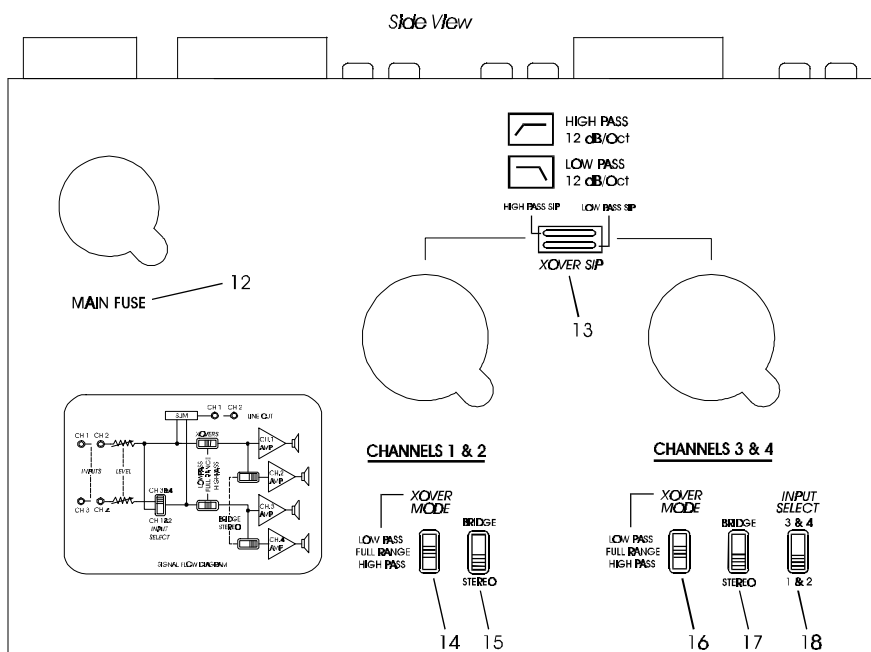
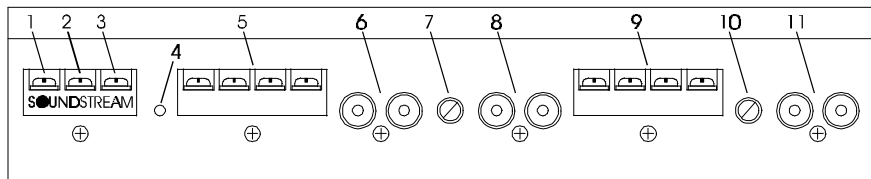
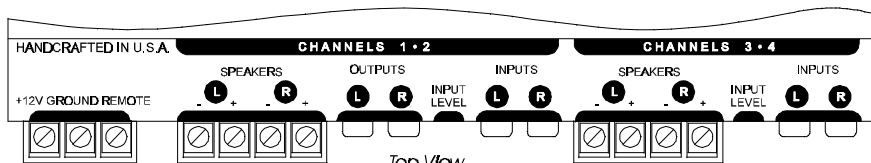

HEAD UNIT

REAM

USA•364

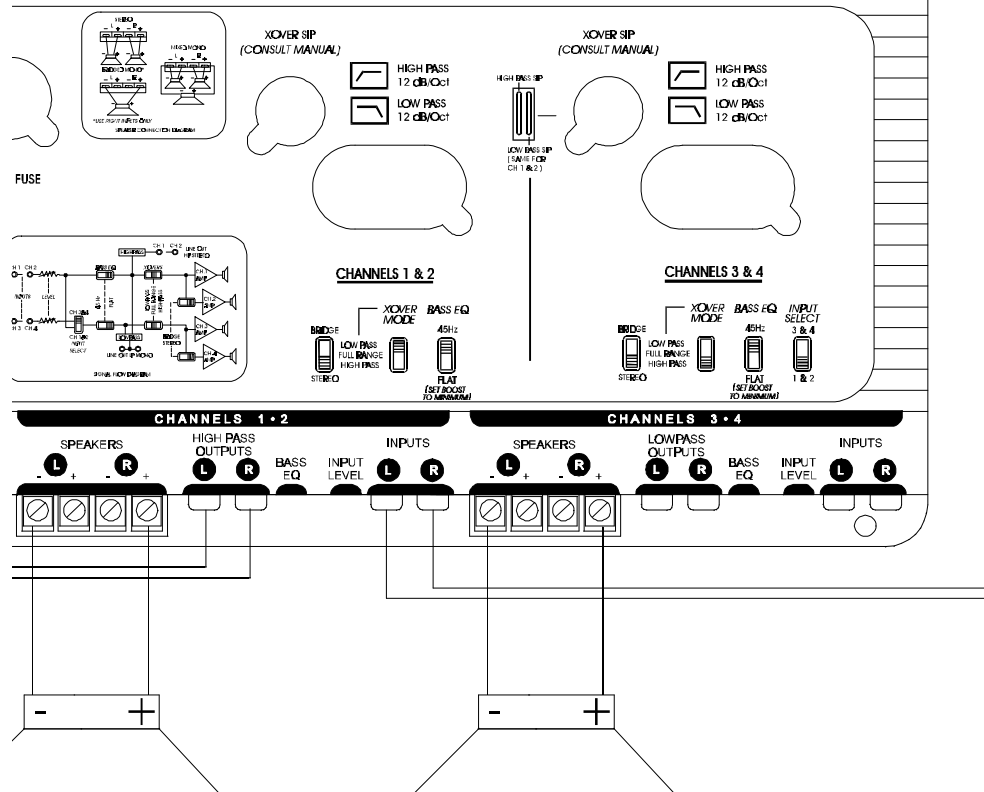

## System Configuration #4:

- One pair of stereo inputs
- Two bridged channels of low pass operation driving subwoofers
- Bass EQ engaged
- High pass RCA output to an external amplifier driving satellites
- Internal crossovers used

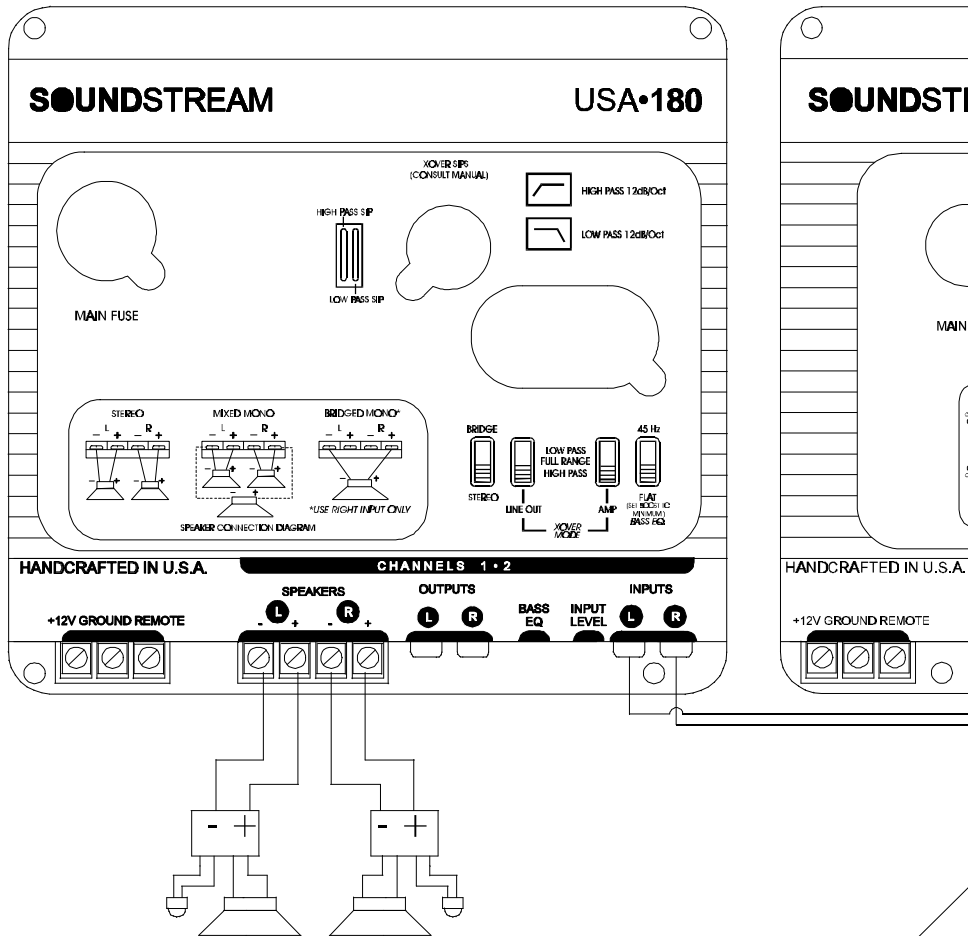
Key to Callouts

1. **+12V** - Connected to fuse or circuit breaker, then battery's positive post.
2. **Ground** - Main ground connection. Bolt to a clean chassis ground in the vehicle.
3. **Remote** - Remote turn-on input from the head unit. Accepts +12V.
4. **LED** - Indicates amplifier power on.
5. **Speaker Output Connections** - Channels 1 & 2.
6. **Signal Output** - Channels 1 & 2; low level full range output to an auxiliary amplifier.
7. **Input Level** - Channels 1 & 2; variable from 100mV to 2.5V.
8. **Inputs** - Channels 1 & 2; right and left channel inputs; only right channel input used in "Mono" mode.
9. **Speaker Output Connections** - Channels 3 & 4.
10. **Input Level** - Channels 3 & 4; variable from 100mV to 2.5V.
11. **Inputs** - Channels 3 & 4; right and left channel inputs; only right channel input used in "Mono" mode.
12. **[underside] Main Fuse** - Main power supply fuse. Replace only with same fuse value.
13. **[underside] Crossover S.I.P.s** - Crossover frequency settings for amplifier.
14. **[underside] Amplifier Crossover** - Channels 1 & 2; Select high pass, low pass, or full range operation.
15. **[underside] Stereo/Bridged Mono Switch** - Channels 1 & 2; Select "Bridge" for bridged mono operation (use right channel input) or "Stereo" for 2-channel Stereo or Mixed Mono operation.
16. **[underside] Amplifier Crossover** - Channels 3 & 4; Select high pass, low pass, or full range operation.
17. **[underside] Stereo/Bridged Mono Switch** - Channels 3 & 4; Select "Bridge" for bridged mono operation (use right channel input) or "Stereo" for 2-channel Stereo or Mixed Mono operation.
18. **[underside] Input Select** - Channels 3 & 4; selectable inputs from internal (from channels 1 & 2) or external.

USA•364

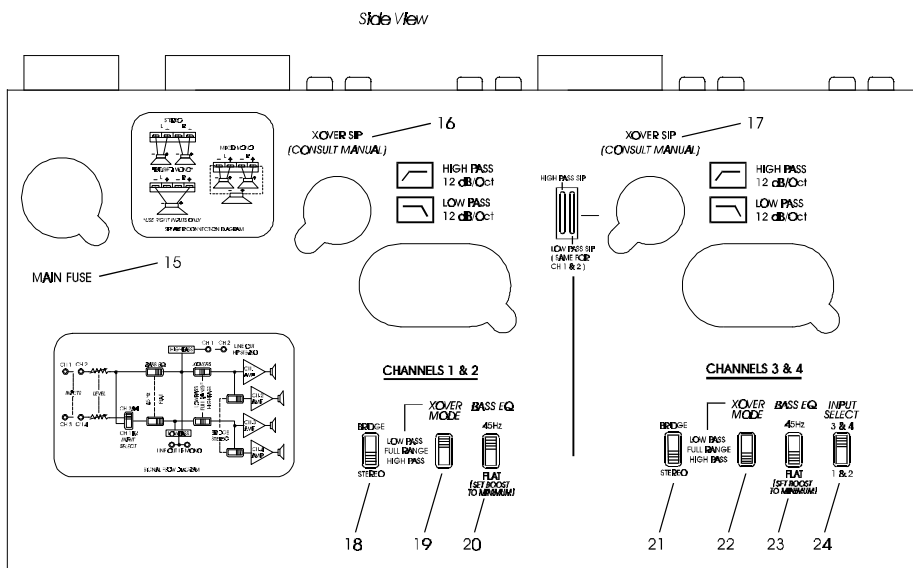
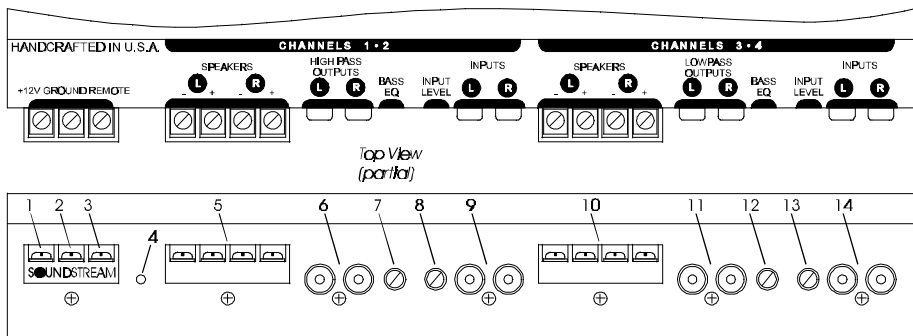

HEAD UNIT

REAM

USA•364

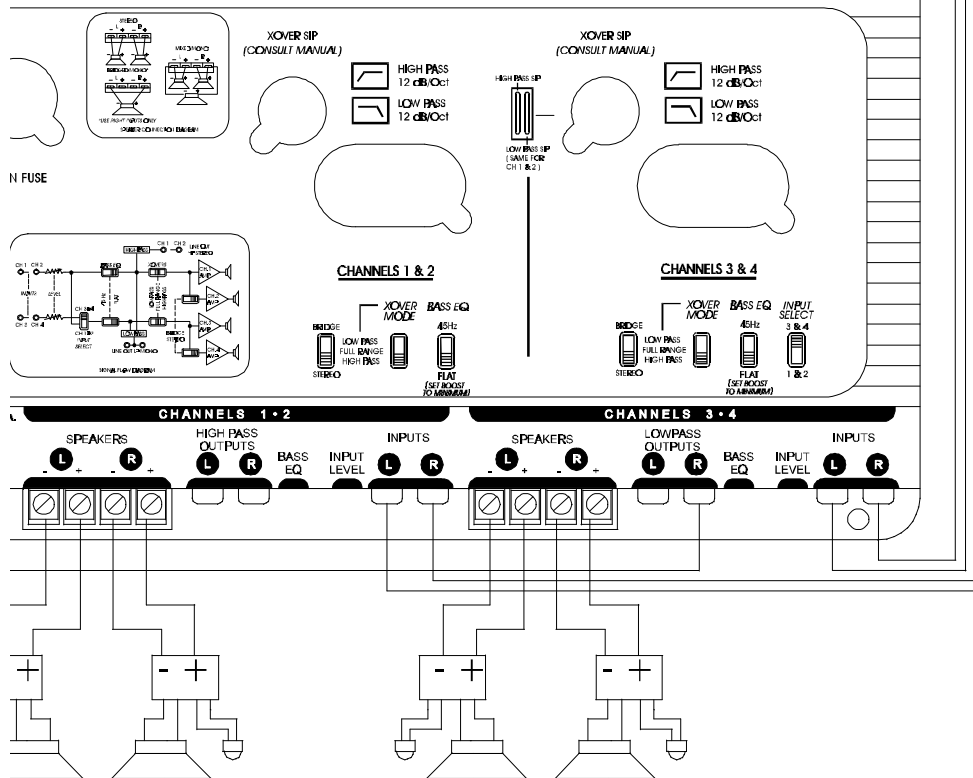

## System Configuration #3:

- Two pairs of stereo inputs
- Four channels driving satellites in high pass
- Low pass RCA outputs to an external amplifier driving a subwoofer
- Internal crossovers used

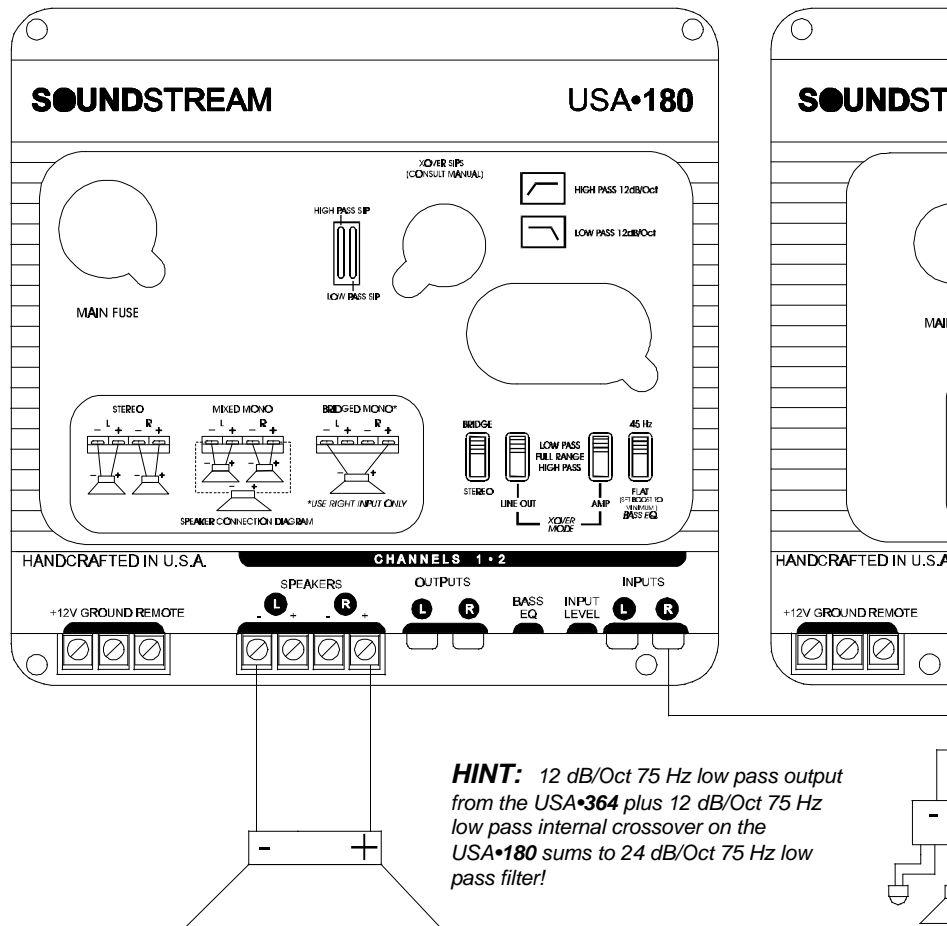
Key to Callouts

1. **+12V** - Connected to fuse or circuit breaker, then battery's positive post.
2. **Ground** - Main ground connection. Bolt to a clean chassis ground in the vehicle.
3. **Remote** - Remote turn-on input from the head unit. Accepts +12V.
4. **LED** - Indicates amplifier power on.
5. **Speaker Output Connections** - Channels 1 & 2
6. **High Pass Crossover Output** - Low level high pass outputs to auxiliary amplifier.
7. **Bass EQ** - Adjustable bass equalization circuit, 0 to +9 dB boost at 45 Hz—Channels 1 & 2.
8. **Input Level** - Variable from 100mV to 2.5V—Channels 1 & 2.
9. **Inputs** - Right and left channel inputs; only right channel input used in "Mono" mode—Channels 1 & 2.
10. **Speaker Output Connections** - Channels 3 & 4
11. **Low Pass Crossover Output** - Low level low pass output to auxiliary amplifier.
12. **Bass EQ** - Adjustable bass equalization circuit, 0 to +9 dB boost at 45 Hz—Channels 3 & 4 & low pass output.
13. **Input Level** - Variable from 100mV to 2.5V—Channels 3 & 4.
14. **Inputs** - Right and left channel inputs; only right channel input used in "Mono" mode—Channels 3 & 4.
15. **[underside] Main Fuse** - Main power supply fuse. Replace only with same fuse value.
16. **[underside] Xover S.I.P.s** - Crossover frequency settings for amplifier and outputs—Channels 1 & 2 & high pass and low pass outputs.
17. **[underside] Xover S.I.P.s** - Crossover frequency settings for amplifier and outputs—Channels 3 & 4 & low pass outputs.
18. **[underside] Stereo/Bridged Mono Switch** - Select "Mono" for bridged operation (use only right channel input) or "Stereo" for 2-channel Stereo or Mixed Mono operation; See crossover section for more details—Channels 1 & 2.
19. **[underside] Amplifier Crossover Switch** - Select high pass, low pass, or full range operation—Channels 1 & 2.
20. **[underside] Bass EQ Switch** - On/Off switch for bass equalization circuit—Channels 1 & 2.
21. **[underside] Stereo/Bridged Mono Switch** - Select "Mono" for bridged operation (use only right channel input) or "Stereo" for 2-channel Stereo or Mixed Mono operation; See crossover section for more details.
22. **[underside] Amplifier Crossover Switch** - Select high pass, low pass, or full range operation—Channels 3 & 4.
23. **[underside] Bass EQ Switch** - On/Off switch for bass equalization circuit—Channels 3 & 4.
24. **[underside] Input Select** - Selectable inputs from internal (from channels 1 &

**DESIGN FEATURES**

- ◆ **Hand-crafted in the U.S.A.** with mil-spec glass epoxy circuit boards, low-loss connections, gold-plated input connectors, and metal film resistors.
- ◆ **Darlington High Current Output Topology** - Soundstream's "overbuilding" of the output section incorporates Darlington output devices sandwiched between the circuit board and the heatsink in a design called Chassisink™ to ensure cool, efficient amplifier operation.
- ◆ **Mixed Mono Capable** so you can simultaneously drive a stereo and mono load (satellites and subwoofer).
- ◆ **2 Ohm Drive Ability** - Soundstream USA amplifiers are designed to drive loads down to 2 Ohms stereo (4 channel mode) and 4 Ohms bridged.
- ◆ **Built-in Staggered Crossover** - Built in 2-way electronic crossover is designed to send either high or low pass information to the amplifier. Crossover outputs are included on the USA•364 to drive another amplifier with either high or low pass information. RCA outputs are included on the USA•204 to drive another amplifier with full range information.
- ◆ **Bass EQ (USA•364 only)** - Adjustable bass equalization circuit allows you to boost bass by as much as +9 dB at 45 Hz. A built-in subsonic filter helps to protect speakers.
- ◆ **Drive Delay™ Muted Turn-on/off Circuit** - A unique circuit which completely eliminates any amplifier-related turn-on/off noises.
- ◆ **Flexible Input Sensitivity** - Accepts input voltages from 100 mV to 2.5 V, which permits maximum output from amplifier with virtually any source unit.
- ◆ **Differential Balanced Input Topology** for added immunity to ground loops caused by component and vehicle electrical system interaction.

	<i>Stereo Power 4 ohms</i>	<i>Stereo Power 2 ohms</i>	<i>Bridged Power 4 ohms</i>
USA•204	40w x 4	60w x 4	100w x 2
USA•364	60w x 4	90w x 4	180w x 2

- System Configuration #2:
- One pair of RCA inputs
  - Two channels in high pass driving satellites
  - Two channels in low pass driving one subwoofer with bridged-mono wiring
  - Internal crossovers used
  - Internal inputs to channels 3 & 4

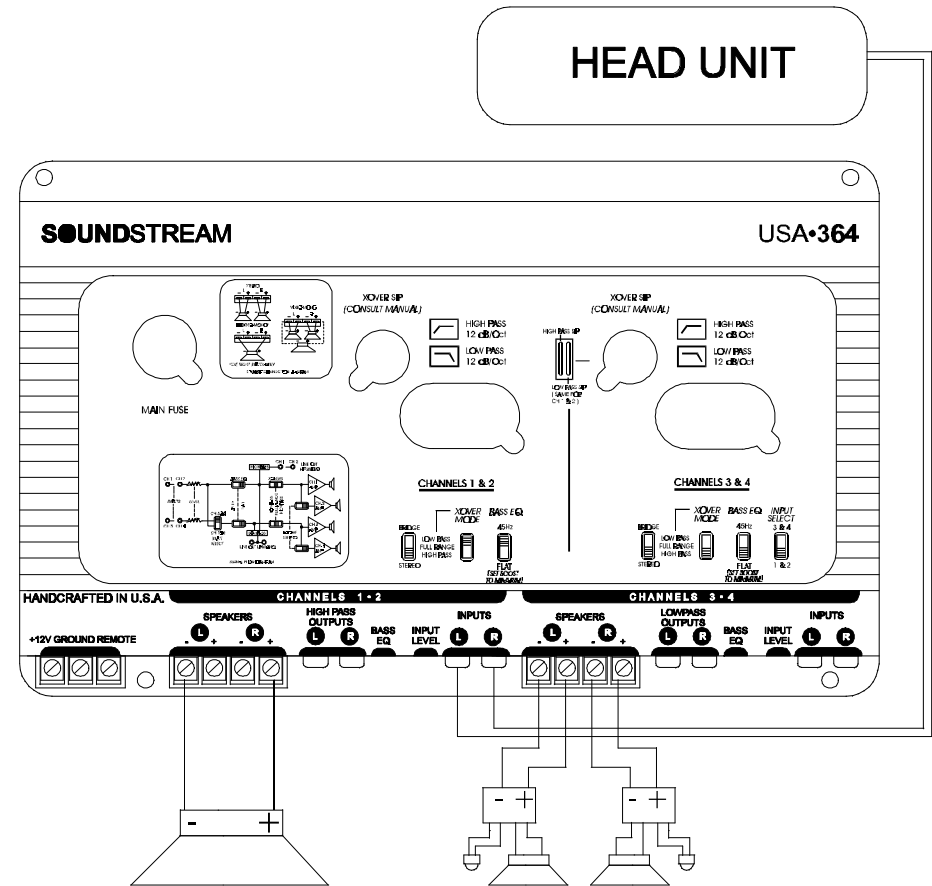

System Configuration #1:

- Two pairs of RCA inputs
- Two channels in high pass driving satellites
- Two channels in low pass driving subwoofers
- Internal crossovers used

HEAD UNIT

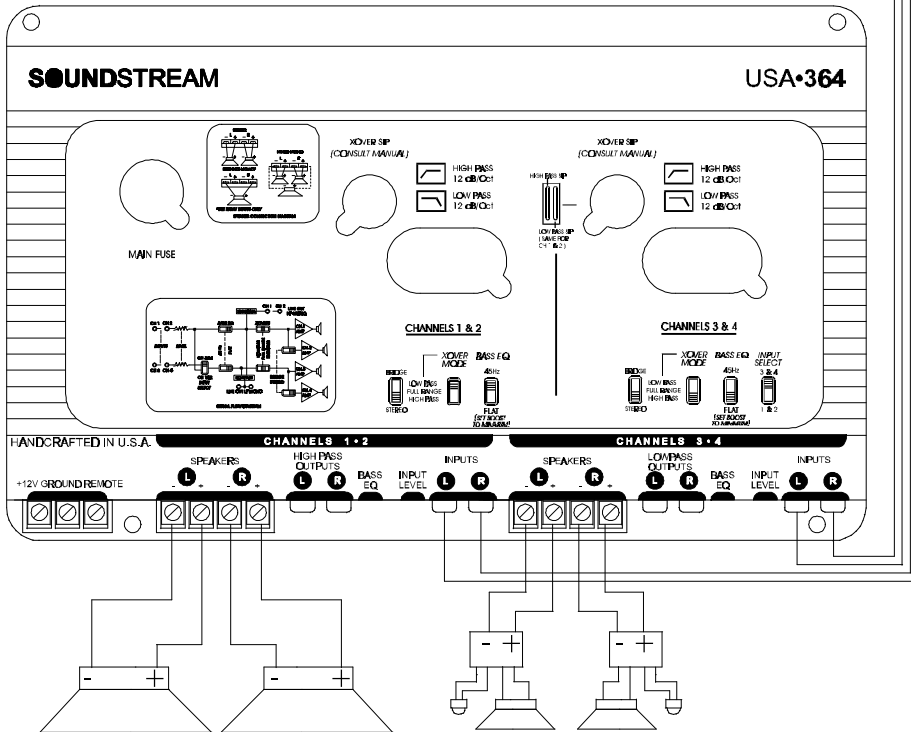

# INSTALLATION STEP 1

## SETTING THE CROSSOVER MODES

The Soundstream USA•204 & 364 incorporate a defeatable electronic crossover for each pair of channels. The USA•364 amplifier includes crossover outputs that can drive a complete system without need of an outboard electronic crossover. The USA•204 includes full range outputs that can drive an external amplifier containing its own internal crossover.

Before installing the amplifier, make certain the switches on the bottom are set to the correct positions.

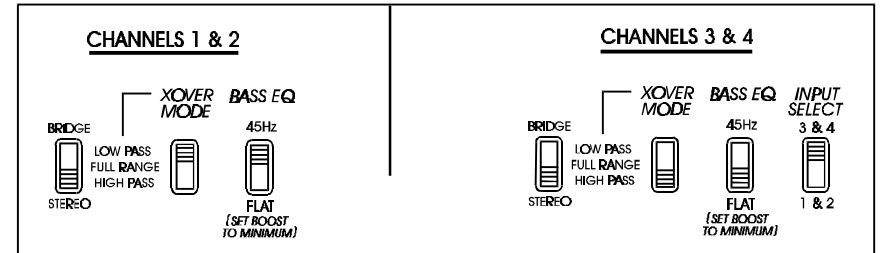

USA•364 shown

### **LOW PASS**

The low pass crossover is used for sending only low frequency information to particular speakers. Activate the low pass crossover if you intend to drive subwoofers.

### **HIGH PASS**

The high pass crossover is used for sending only midrange and high frequency information to specific speakers. Activate the high pass crossover if you intend to drive satellite or coaxial speakers in the system. Even if your system does not include subwoofers, it may be helpful to activate the high pass crossover with smaller speakers to protect them from low frequency information.

# CROSSOVER ADJUSTMENTS

In most car audio installations, there is a tendency for a “midbass boom.” Because of their interior dimensions, most cars will resonate or ring at these midbass frequencies. If we design the system so there is less musical information in this region, the final response is very smooth and natural sounding.

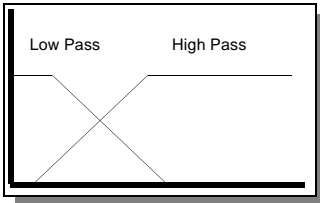

The USA•204 and USA•364 amplifiers incorporate a staggered electronic crossover. The high and low pass portions of the crossover can be set independent of one another.

**Staggered Crossover**  
 12 dB/octave low pass  
 12 dB/octave high pass

Below is a chart of S.I.P. values which can be used for changing the factory preset crossover points.

FREQUENCY	RESISTOR VALUE	COLOR CODE
53 Hz	30 K Ω	Green-Green
73 Hz	22 K Ω	Green-White
89 Hz	18 K Ω	
107 Hz	15 K Ω	Violet-Green
145 Hz	11 K Ω	Violet-White
195 Hz	8.2 K Ω	
286 Hz	5.6 K Ω	
485 Hz	3.3 K Ω	
800 Hz	2.0 K Ω	



**NOTE:** The following formula may be used to determine values in creating “custom” resistor packs. The frequency is equal to 1,600,000 divided by the individual resistor value, or  $1,600,000 / R \text{ ohms} = X \text{ Hz}$ . To make a custom S.I.P., use 4 identically valued resistors of 2% or tighter tolerance. See the drawing of the S.I.P. for more information.  
 Example:  $1,600,000 / 22,000 = 73 \text{ Hz}$

# HEAD UNIT

REAM

USA•204

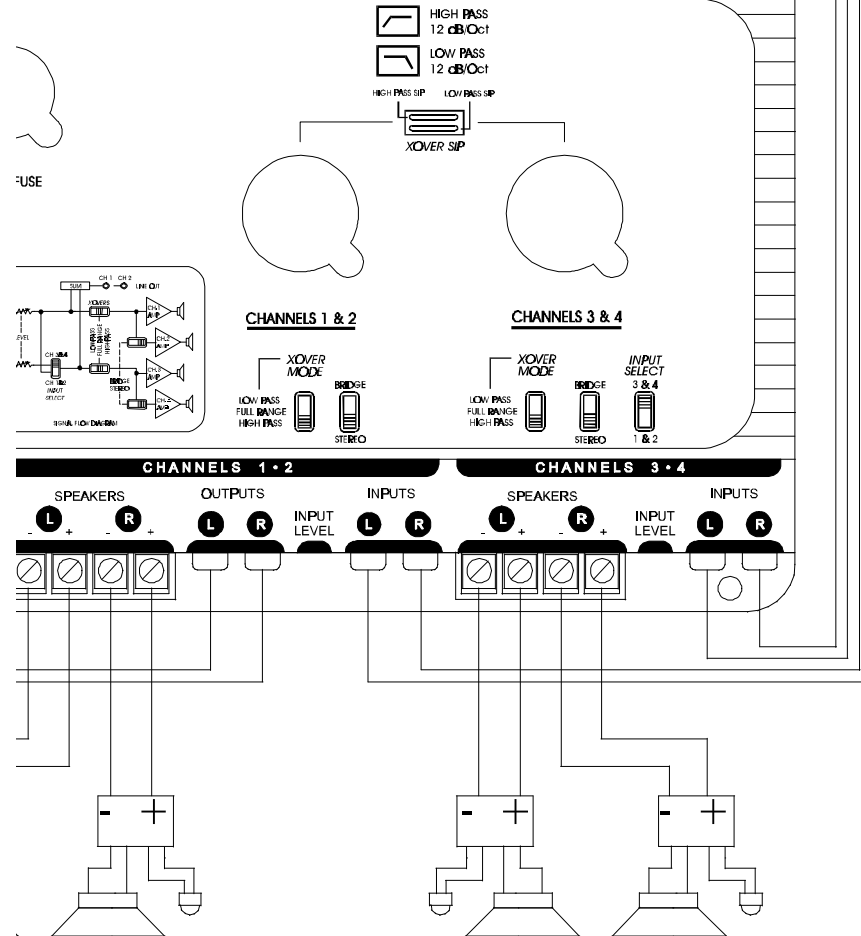

System Configuration #3:

- Two pairs of stereo inputs
- Four channels of high pass stereo operation
- Full range output to an external amplifier driving a subwoofer
- External amplifier utilizing its own built-in crossover

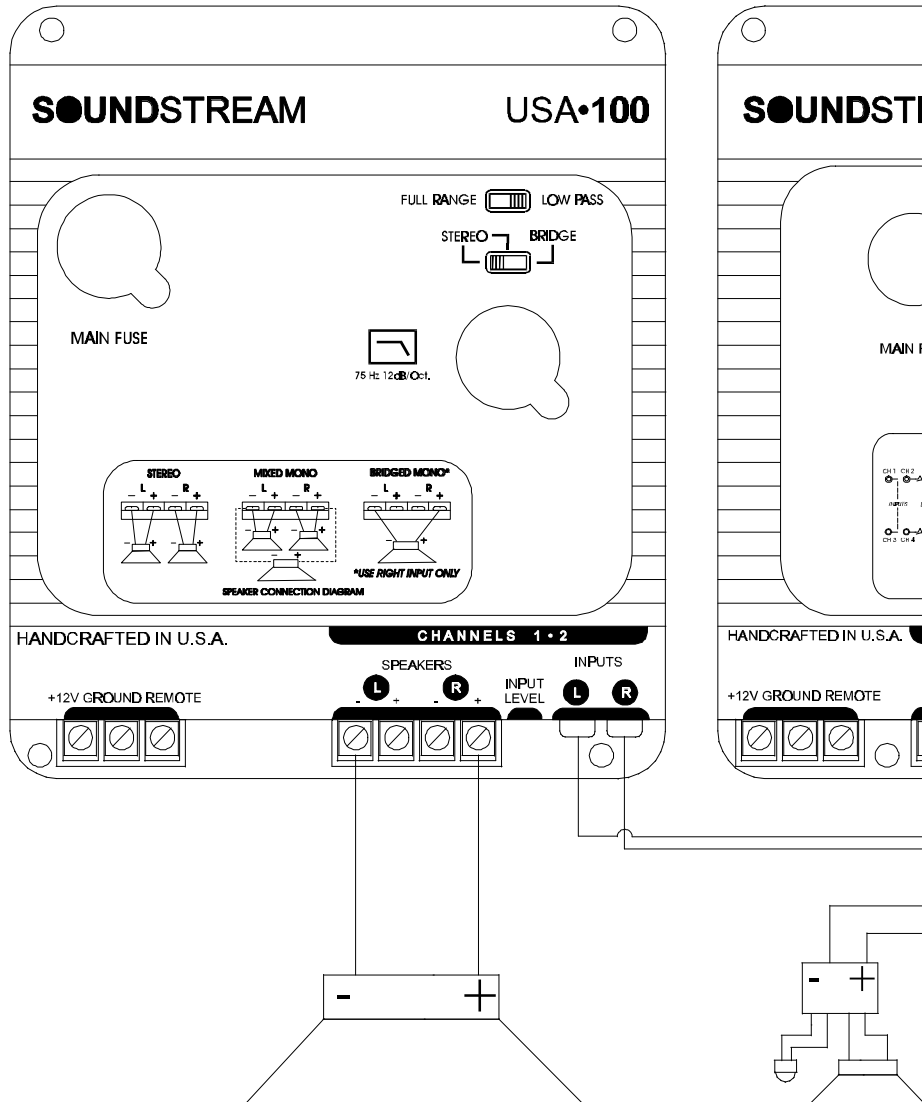

**SELECTING INPUT MODES**

On Soundstream amplifiers, a pair of channels may be bridged for mono operation. To do so, simply put the stereo switch into the "mono" position and follow the mono wiring (Right Positive goes to speaker's positive; Left Negative goes to speaker negative).

**Stereo** for normal operation.

**Mixed-Mono** in order to drive stereo and mono simultaneously; works well for center channels. It can be used anytime you need a summed mono channel (i.e., With this switch in *stereo* and using bridged output wiring, left and right channel information will be summed into a single mono load. This is ideal for using stereo inputs to drive a mono subwoofer!)

**Bridged Mono** for dedicated single channel operation; ideal for driving a subwoofer with a mono input. It is also used when large amounts of power are necessary for single speakers. ***In bridged mono, only the right channel input is active.***

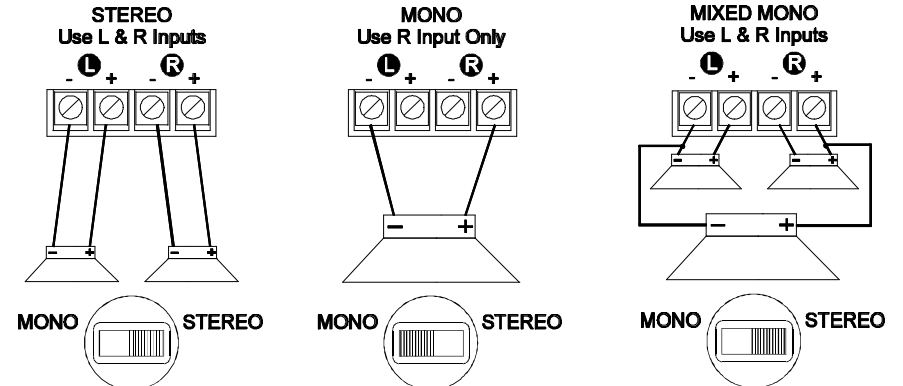

*In bridged mono, only the right channel input is active.*

**For system examples and diagrams, see pages 16 - 21.**

# INSTALLATION STEP 3

## WIRING

### POWER AND GROUND

To assure maximum output from your amplifier, use high quality, low-loss power and ground cables. Soundstream USA amplifiers incorporate gold-plated barrier strips for maximum power transfer and protection from corrosion. The screw terminals back out for use with spade & ring terminals, as well as bare wire. Determine from the chart below the minimum gauge power and ground wire for your application.

	up to 10'	up to 20'
USA•204	Soundstream Power80 or Power100	Soundstream Power80 (8 ga.)
USA•364	Soundstream Power80 or Power100 (or 8 or 10 ga.)	Soundstream Power80 (8 ga.)

### CIRCUIT BREAKERS/FUSES

#### EXTERNAL

Like all audio components, the Soundstream amplifiers must be fused near the battery. A fuse or circuit breaker must be located within 18" of the battery. This will prevent a fire in the event of a shorted cable. **See the chart below to determine the value of your battery fuse/circuit breaker.**

Model	Amplifier Fuse(s)	Battery Fuse/ Circuit Breaker
USA•204	25 amp automotive	30 amp
USA•364	(2) 20 amp automotive	50 amp

(Continued on page 13)

# USA•204

### System Configuration #2:

- One pair of stereo inputs
- Two channels driving satellites in high pass
- Two channels driving one subwoofer with bridged mono wiring
- Internal crossovers used

## HEAD UNIT

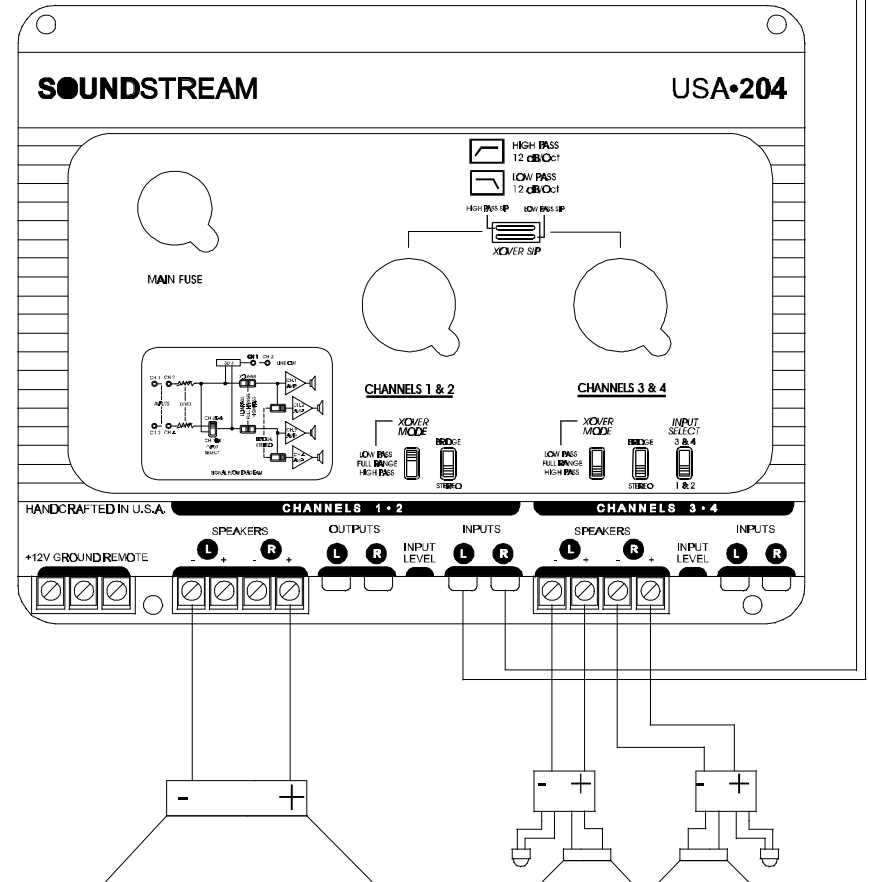

System Configuration #1:

- Two pairs of stereo inputs
- Four channels driving satellites in full range

HEAD UNIT

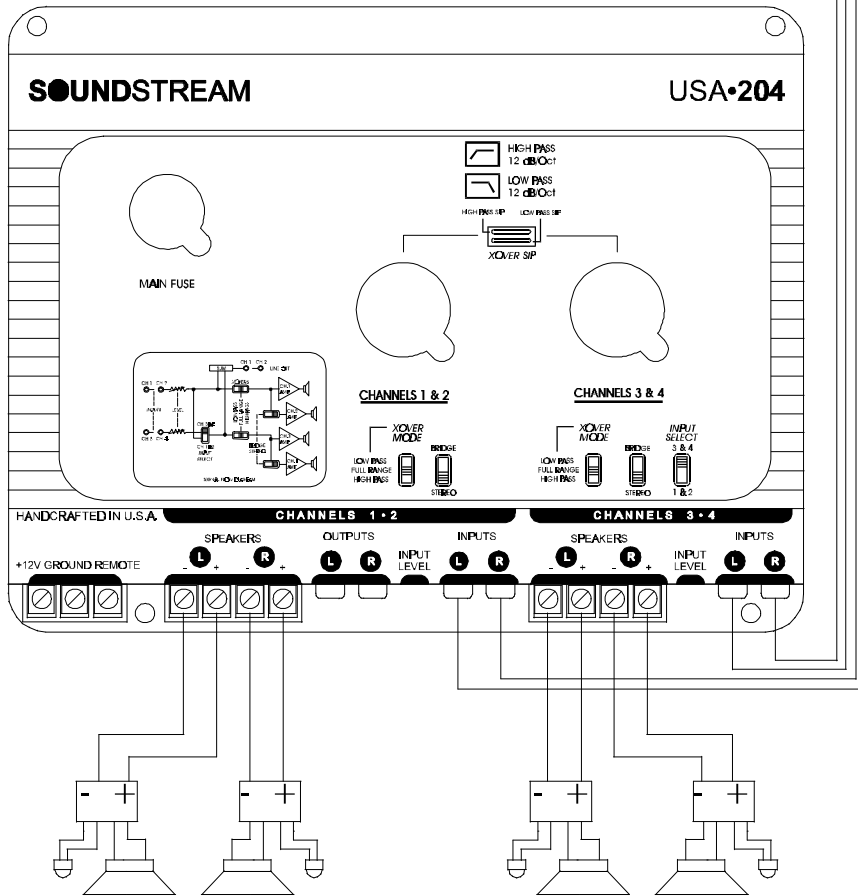

(Continued from page 12)

**INTERNAL**

The Soundstream amplifiers are fused internally with automotive-type fuses. The fuses are accessible via a plastic plug on the bottom of the amplifier. **Never replace the fuses with a higher value than what is supplied. This may result in amplifier damage and will void the warranty!**

**REMOTE TURN-ON**

Connect the "Remote" to the turn-on lead from the source unit. When +12 volts is received, the amplifier will turn on. Soundstream's Remote200 20 gauge turn on lead works perfectly.

**SIGNAL CABLE**

To guarantee optimum performance, use a high-quality cable that will be easy to install and has minimal signal loss such as Soundstream's DL 1 or SL 1.

**SPEAKER CABLE**

Use a high quality, flexible, multi-strand cable for best performance and

**WIRING DIAGRAM**

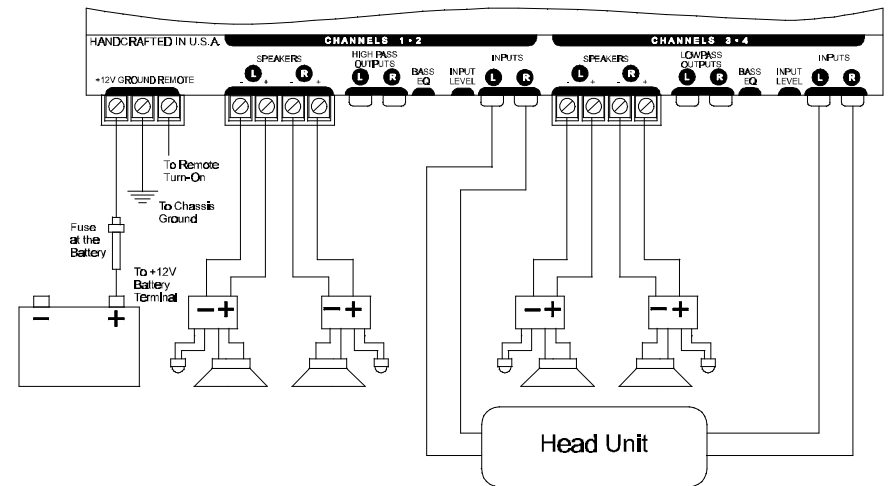

USA•364 wiring shown

# INSTALLATION STEP 4

## INSTALLATION AND MOUNTING

### 1. **AMPLIFIER LOCATION**

The USA amplifiers employ highly efficient circuitry and a unique Chassisink™ design to maintain lower operating temperatures. Additional cooling may be required if the amplifier is located in a tightly confined area, or when driving especially low impedance loads at extremely high levels.

When mounting the amplifier, it should be securely mounted to either a panel in the vehicle or an amp board or rack that is securely mounted to the vehicle. The mounting location should be either in the passenger compartment or in the trunk of the vehicle, away from moisture, stray or moving objects, and major electrical components. To provide adequate ventilation, mount the amplifier so that there are at least two inches of freely circulating air above and to the sides of it.

### 2. **SWITCHES**

Set Input and Crossover switches to the appropriate positions (see pages 16 - 25).

### 3. **MOUNTING THE AMPLIFIER**

- Using the amplifier as a template, mark the mounting surface.
- Remove the amplifier and drill the holes.
- Mount the amplifier to the surface using the provided hardware.

### 4. **WIRING**

- Run and connect the audio signal and remote turn-on cables to the amplifier from the source unit.
- Carefully run the positive cable from the amplifier to a fuse or circuit breaker within 18 inches of the battery.**
- Then connect the fuse or circuit breaker to the battery. Leave the circuit breaker off or the fuse out until everything is bolted down.
- Secure the ground cable to a solid chassis ground on the vehicle. It may be necessary to sand paint down to raw metal for a good connection.
- Double check each and every connection!
- Re-connect the fuse or circuit breaker.

### 5. **POWER UP**

Power up the system and look at the LED and it should be lit. There may be a 2 - 3 second delay from the time the source unit is turned on to the time the LED on the amp turns on, which is normal. Once the amplifier power LED is on and the source unit is playing, you should have sound coming from the speakers.

# INSTALLATION STEP 5

## LEVEL SETTING

The input levels are adjusted by means of the input level controls located on the front of the amplifier.

In the ideal situation, all components in the audio system reach maximum undistorted output at the same time. The reason is because an amplifier will only make what comes into it bigger. So, if you send it a distorted signal from the head unit, it is going to amplify distorted information. The same thing holds true if an outboard processor or crossover begins to distort before you have maximum output from the amplifier. By setting all components to reach clipping at the same time, you can maximize the output of your system.

Follow the below procedure for the quickest, easiest means of setting the levels:

- Turn the amp's input levels to minimum position (fully counter-clockwise).
- Set source unit volume to approximately 3/4 of full volume.
- While playing dynamic source material, slowly increase the amplifier's input level until a near maximum undistorted level is heard in the system.

**NOTE:** Even though the S/N ratio with low output sources is better with the Soundstream amplifiers than others, your best combination of output level and Signal to Noise ratio will be achieved when the input levels are set between 500 mV and 2.5 V.

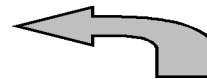

### **Installation with Plexiglass Bottom Plates**

*Plexiglass bottom plates are available for all USA amplifiers. They are designed to enhance the cosmetics of virtually any installation by proudly displaying the USA flag circuit board, and American made circuitry!*

*When installing a USA amplifier with a plexiglass bottom plate, try to make certain that the amplifier receives adequate ventilation. You can do this by mounting the amplifier in such a way that the heat sink fins are oriented vertically. If the amplifier is to be mounted horizontally, a +12V fan can be*